



MIKUNI CARBURETORS HI-PERFORMANCE SUPER BN

Extended Throttle Shaft Without Choke Shaft



38MM
Part # **BN38-34-8113**



44MM
Part # **BN44-40-8067**



44MM
Part # **BN44-40-8052**



46MM
Part # **BN46-42-8002**



OEM REPLACEMENT SUPER BN

Regular Throttle Shaft With Choke Shaft

*** Direct replacement of OEM Carburetors at a fraction of OEM cost. ***

MAG-SIDE



40MM – I-SERIES

MAG-SIDE (FRONT)

Part # **BN40I-38-26**

PTO-SIDE (REAR)

Part # **BN40I-38-27**

Sea Doo 720 GTI, GTS, GS, GSI '98, 800 GTX, GSX '96-'00, 800 SPX 97-99, 800 XP '95-'99, 951 GSX LTD '97

PTO-SIDE



38MM

Part # **BN34-28-8010**

Yamaha

Wave Runner 500 88-89

Wave Jammer 500 88-89



40MM – I-SERIES

Part # **BN40I-38-24**

Sea Doo 720,
GTI, GTS, GS, GSI, '97



44MM

Part # **BN44-40-43**

Yamaha Superjet,
Wave Blaster, Tigershark

DUAL CARBURETOR SET

46MM – I-SERIES

Part # **BN46I-42-B4**

Sea Doo 951,
GSX, GTX, XP-LTD, '98-01, XP'00, RX, LRV

Note: Sold as a fully assembled dual carburetor set.





GENUINE CARBURETOR REBUILD KITS

Kits include all necessary gaskets, diaphragms, and hardware required to disassemble and rebuild Mikuni carburetor.

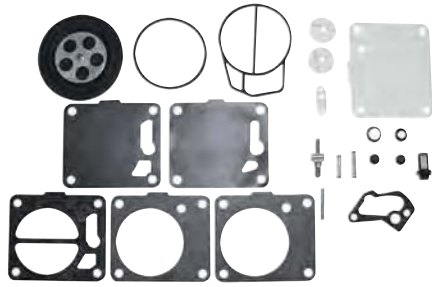

Kit Includes Mikuni Arm Springs (1 each - 65gm & 115gm)

Mikuni	Diaphragm Cover	Part No.
Super BN	Square	MK-BN38/44 SPR
38mm, 44mm, 46mm and I Series 38/40		

*Sea Doo Pre 97, Kawasaki 750 98-02, 800 SX-R 03-08 and ALL Mikuni Performance Super BN Square Body 38mm, 44mm and 46mm carbs

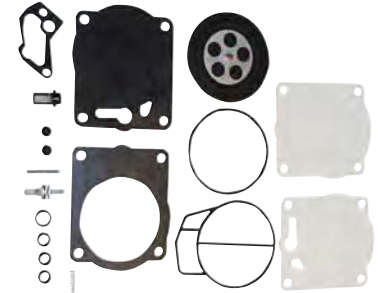

Kit Includes Mikuni Arm Spring (1 spring - 95gm)

Mikuni	Diaphragm Cover	Part No.
I Series 46mm	Square	MK-BN461
*Sea Doo 951 (98 and newer)		



Kit Includes Mikuni Arm Spring (1 spring - 95gm)

Mikuni	Diaphragm Cover	Part No.
I Series 44mm/46mm	Square	MK-BN44I-YAM

*Yamaha GP800 98-99, GP 800R 00-05, XL 800 01, XLT 800 02-04, GP 1200R 00-02, XL1200 Limited 99-00 and XLT 1200 01-05 **Yamaha Engine Type 60T, 66E, 66V, 67X, 68N**

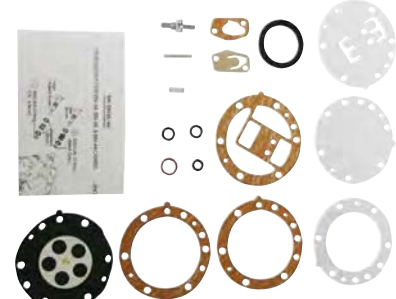

Kit Includes Mikuni Arm Spring (1 spring - 95gm)

Mikuni	Diaphragm Cover	Part No.
BN 38mm, 44mm	Round	MK-BN38/44

*BN carbs are "Old Style/Round Body" with round diaphragm covers

MIKUNI SUPER BN SPECIFICATIONS

Carb Type	Mikuni Part No.	Low Speed Jet	High Speed Jet	Needle Valve	Arm Spring (Grams)	Choke Carb Primer	Color
SBN38	BN38-34-8113	65	107.5	2.0	115 grams	Primer	Silver
SBN44	BN44-40-8052	100	125	2.3	65 grams	Primer	Black
SBN44	BN44-40-8067	120	140	2.5	80 grams	Primer	Silver
SBN46	BN46-42-8002	120	150	2.5	80 grams	Primer	Silver
OEM Yamaha SBN44	BN44-40-43	120	115	1.5	115 grams	Choke	Black
OEM Yamaha SBN38	BN34-28-8010	77.5	80	1.5	65 grams	Choke	Black
I series 44	BN40I-38-24	70	167.5	1.5	95 grams	Choke	Black
I series 40 (Mag-Side Front)	BN40I-38-26	67.5	140	1.5	95 grams	Choke	Black
I series 40 (PTO-Side Rear)	BN40I-38-27	67.5	142.5	1.5	95 grams	Choke	Black
Sea Doo Dual I Series 46	BN46I-42-B4	77.5	162.5	2.0	95 grams	Choke	Black

FOUR STROKE
INTAKE SYSTEMS
ENGINE/GASKETS
EXHAUST
DRIVE LINE HANDLING
ELECTRICAL
WATERLINE /BILGE
STEERING & CONTROLS
BODY
ACCESSORIES SERVICE TOOLS
/HARDWARE
CHEMICAL

MIKUNI GENUINE PARTS

Diagram No.	Description	Mikuni Part No.
1.	Gasket Pump (2)	BN38/547
1a.	O-Ring*	.616-72001
2.	Diaphragm, Pump (Clear)	BN34/97
3.	Check Valve (2) (Clear)	BN34/124
4.	Grommet, Check Valve (2)	BN34/125
5.	Diaphragm, Damper (large hole)**	BN34/100
5a.	Diaphragm, Damper (small hole)*	BN34/129
6.	Gasket, Damper**	BN34/101
6a.	O-Ring*	.616-92007
7.	Filter	BN44/146
8.	O-Ring, Hi Speed	B30/305
9.	O-Ring, Low Speed	MD12/16
10.	O-Ring, Needle Valve	not available
11.	Gasket Valve Body	BN34/123
12.	Check Valve (Clear)	BN34/107
13.	Spring, Arm (115 grams)	see pg 98
13a.	Spring, Arm (65 grams)	see pg 98
13b.	Spring, Arm (95 grams)	see pg 98
14.	Pin, Arm	VM30/97
15.	Arm (Stainless)	BN38/534
16.	Diaphragm Assembly	BN44/145

MK-BN38/44SPR REBUILD KIT

18.	Cover Pump	BN34/95B
19a.	Body Assembly Pump (Must use w/O-Ring 1A)	BN34/128
20.	Stop Screw, Idle**	BN44/109
20a.	Stop Screw, Idle*	BN34/82
21.	Washer (Aluminum - Same as #26)	BN38/39
22.	Spring, Idle**	BN38/341
22a.	Spring, Idle (Same as #25)*	BN38/344
24.	Adjuster, Hi Speed (with Cross Bar)	BN44/167
25.	Spring, Hi Speed (Same as #22a)	BN38/344
26.	Washer, Hi Speed (Aluminum - Same as #21)	BN38/39
27.	Washer, Low Speed (Aluminum)	BN38/172
28.	Spring, Low Speed	BN38/343
29a.	Adjuster, Low Speed (with Cross Bar) 38mm	BN38/477
29b.	Adjuster, Low Speed (with Cross Bar) 44mm	BN38/166
33.	Plate, N.V. Retainer	BN34/117-GG
34.	Screw with washer	CW2-0307-G
35.	Low Jet, 30-160 in increments of 5 (See page 98)	N100.606-SIZE
36.	Main Jet, 30-260 in increments of 5 (See page 98)	N102.221-SIZE
37.	Screw	BV15/121-05-GG
38.	Plate, Valve	BN34/108-GG
39.	Valve Body Assembly	BN44/165
40.	Screw (2 pcs)	C5-0414-G
41.	Screw	C6-0308-G
42.	Cover (Stainless)	BN44/147

*Super BN38 and Late Super BN44
**Early Super BN44



SUPER BN CARBURETOR TUNING MANUAL

For the watercraft tuner working with Super BN series carburetors.

Description	Part No.
Mikuni Tuning Manual	MK-BN/004

Socket Bolt Kit

59-9131

See bottom of page

* Super BN38 and Late Super BN44
** Early Super BN44

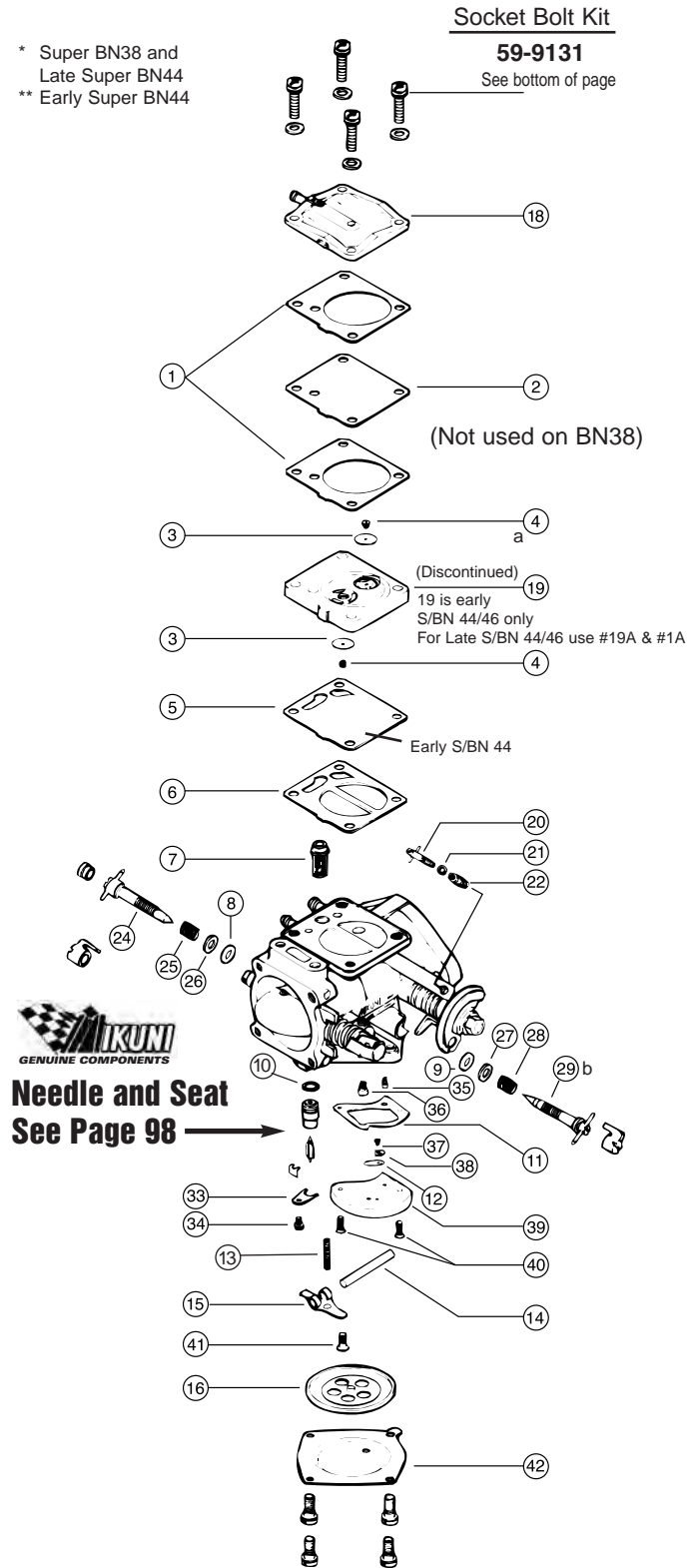

Needle and Seat
See Page 98

SBN CARBURETOR DIAPHRAGM COVER SOCKET BOLT KIT

Replace the stock phillips bolts on carbs with stainless steel socket head bolts.

Description	Part No.
Mikuni Super BN Bolt Kit	59-9131

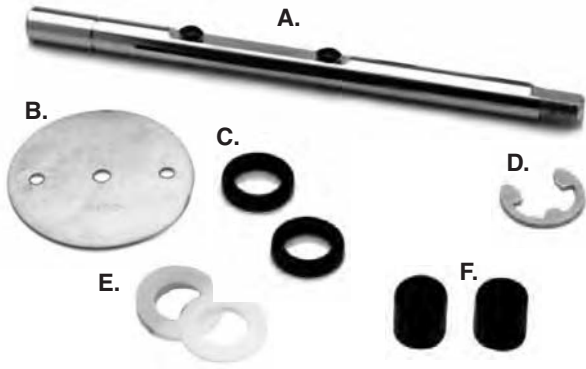

MIKUNI THROTTLE VALVE KIT

Description	Part No.
Throttle valve (#150) kit for 38mm	MK-BN/038 TV
Throttle valve (#120) kit for 44mm	MK-BN/044 TV
Throttle valve (#120) kit for 46mm	MK-BN/046 TV

THROTTLE SHAFTS AND VALVES (ALL PARTS SOLD INDIVIDUALLY - PER PIECE)

Description	Part No.
A. Super BN 44mm Throttle Shaft (Extended)	703-89004
B. Super BN 44mm #120 Throttle Valve	BN44/06-120
B. Super BN 46mm #120 Throttle Valve	818-46009-120
C. Super BN 38/44/46mm Throttle Shaft Seal	N167.126
D. Super BN 38/44/46mm Throttle Shaft Clip (Heavy Duty)	MK-BN/005
E. Super BN 38/44/46mm Throttle Shaft Washer (Nylon)	N114.077
F. Super BN 38/44/46mm Throttle Shaft Bushing	BN38/569

All parts sold individually - per piece



Super BN 38

Also used in late style Super BN 44

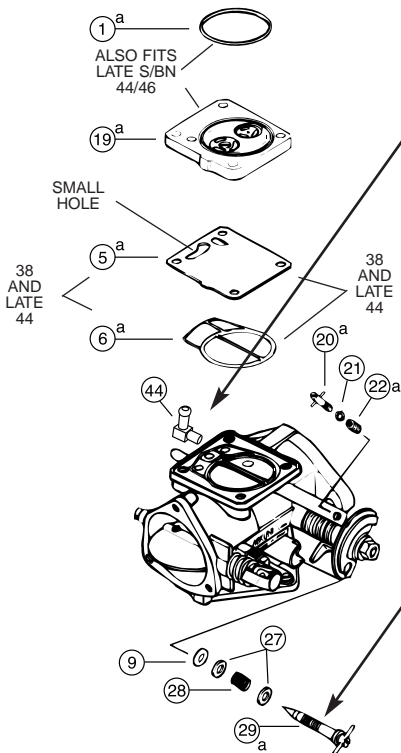

90° FUEL INLET FITTING (PRESS IN)

Description	Diag. #	Part No.
90° Fuel Inlet Fitting	44	DF44-2/70

All parts sold individually - per piece



ADJUSTER WITH CROSS BAR

Description	Diag. #	Part No.
High Speed 38/44	24	BN44/167
Low Speed 38	29a	BN38/477
Low Speed 44	29b	BN38/166

(Does not fit Yam OEM 44mm carb)



DIAPHRAGM AND FILTER

Description	Diag. #	Part No.
G. Diaphragm Assembly	16.	BN44/145
H. Super BN Filter	7.	BN44/146

All parts sold individually - per piece



ULTIMATE CARB GASKETS

Thick "Green" gaskets.

Mikuni	Part No.
38mm	9230
40mm "I" Series	9235
44mm	9240
46mm	9250
48mm	9252
50mm	9257
50mm SD951 "I" Series	6740

FOUR STROKE	INTAKE SYSTEMS	ENGINE/GASKETS	EXHAUST	DRIVE LINE HANDLING	ELECTRICAL	WATERLINE /BILGE	STEERING & CONTROLS	BODY	ACCESSORIES	SERVICE TOOLS /HARDWARE	CHEMICAL
-------------	----------------	----------------	---------	---------------------	------------	------------------	---------------------	------	-------------	-------------------------	----------



PARTS STAMPING This marking on a jetting part is your quality assurance guarantee it is a genuine Mikuni component. **DO NOT ACCEPT SUBSTITUTES.**



CARBURETOR JETS
Mikuni Low Jets
P/# (N100.606-size)

Size:	30	95
	32.5	97.5
	35	100
	37.5	102.5
	40	105
	42.5	107.5
	45	110
	47.5	112.5
	50	115
	52.5	117.5
	55	120
	57.5	122.5
	60	125
	62.5	127.5
	65	130
	67.5	132.5
	70	135
	72.5	137.5
	75	140
	77.5	142.5
	80	145
	82.5	147.5
	85	150
	87.5	155
	90	160
	92.5	

CARBURETOR JETS
Mikuni Main Jets
P/# (N102.221-size)

Size:	30	95	160
	32.5	97.5	162.5
	35	100	165
	37.5	102.5	167.5
	40	105	170
	42.5	107.5	172.5
	45	110	175
	47.5	112.5	177.5
	50	115	180
	52.5	117.5	182.5
	55	120	185
	57.5	122.5	187.5
	60	125	190
	62.5	127.5	195
	65	130	200
	67.5	132.5	205
	70	135	210
	72.5	137.5	215
	75	140	220
	77.5	142.5	230
	80	145	240
	82.5	147.5	
	85	150	
	87.5	152.5	
	90	155	
	92.5	157.5	

Description

Part No.

Dealer Standard Compartment Kit*	53-2120
Performance Compartment Kit	53-2121
Compartment only	53-2122

Dealer Compartment Kit contents:

- 4 Each of Needle and Seat
1.5/2.0/2.3/2.5
- 4 Each of Arm Spring
65/80/95/115gm
- 5 Each of Low Jets
67.5/70/72.5/75/77.5/87.5/90/92.5
95/97.5/100/102.5/105/107.5/110
- 5 Each of Main Jets
105/110/115/120/125/130/135/140
145/150/155/160

Performance Compartment Kit contents:

- 4 Each of Needle and Seat
2.0/2.3/2.5
- 4 Each of Arm Spring
80/95/115gm
- 5 Each of Low Jets
105/110/115/120/125/130/135/140
145/150/155/160
- 5 Each of Main Jets
135/140/145/150/155/160/165/170
175/180/185/190

OLD TYPE NEEDLES & SEATS

**ROUND DIAPHRAGM COVER
STANDARD BN
OLD TYPE, STANDARD METAL TIP**

— Screw in Type —



Description	Part No.
1.5	VM26/26-1.5
2.0	VM26/26-2.0
2.3	VM26/26-2.3
2.5	VM26/26-2.5
2.8	VM26/26-2.8

NEW TYPE NEEDLES & SEATS

SQUARE DIAPHRAGM COVER SUPER BN (NEW TYPE)

— Push in Type —



VITON TIP

Recommended for Gas Fuel Applications

Description	Part No.
1.2	—
1.5	786-35015-1.5
1.8	786-35015-1.8
2.0	786-35015-2.0
2.3	786-35015-2.3
2.5	786-35015-2.5

STANDARD METAL TIP

Recommended for Alcohol Fuel Applications

Description	Part No.
1.2	786-35018-1.2
1.5	786-35018-1.5
1.8	786-35018-1.8
2.0	786-35018-2.0
2.3	786-35018-2.3
2.5	786-35018-2.5

MIKUNI ARM SPRINGS

Description	Color	Part No.
65 grams	Shiny Silver	730-03030
80 grams	Black	730-03033
95 grams*	Platinum	730-03034
*This 95gm spring is for Sea Doo BN 46l Carbs Only!		
95 grams	Dull Silver	730-03027-T
115 grams	Platinum	730-03027

POP-OFF PRESSURE CHART

Part No.	730-03027	730-03027-T	730-03033	730-03030
Arm Springs	115 grams	95 grams	80 grams	65 grams
Needle Valve Size	1.5	55 p.s.i.	43 p.s.i.	38 p.s.i.
	2.0	32 p.s.i.	25 p.s.i.	21 p.s.i.
	2.3	22 p.s.i.	20 p.s.i.	17 p.s.i.
	2.5	19 p.s.i.	17 p.s.i.	14 p.s.i.
Color	Platinum*	Dull Silver	Black	Shiny Silver

*The new color "platinum" color is due to increasing emission regulations in Japan. The new treatment process of the springs creates the new color.



FOUR STROKE
INTAKE SYSTEMS
ENGINE/GASKETS
EXHAUST
DRIVE LINE HANDLING
ELECTRICAL
WATERLINE /BILGE
STEERING & CONTROLS
BODY
SERVICE TOOLS ACCESSORIES /HARDWARE
CHEMICAL

MIKUNI GENUINE PARTS SUPER BN 46 "I"

Diagram No.	Description	Mikuni Part No.
4.	Grommet, Check Valve (2)	BN34/125
7.	Filter	BN44/146
8.	O-Ring, Hi Speed (2)	B30/305
9.	O-Ring, Low Speed (2)	MD12/16
11.	Gasket Valve Body	BN34/123
12.	Check Valve (Clear)	BN34/107
14.	Pin, Arm	VM30/97
15.	Arm (Stainless)	BN38/534
16.	Diaphragm Assembly	BN44/145
61.	Gasket, Pump	BN46I/13
62.	Diaphragm, Pump (Clear)	BN46I/14
63.	O-Ring	616-73002
64.	Check Valve (2)	BN46I/11
66.	Diaphragm, Damper	BN46I/34
67.	Diaphragm, Damper (clear)	BN46I/15
68.	O-Ring	616-73003
69.	O-Ring, Needle Valve	KV/10

MK-BN46I Rebuild Kit

21.	Washer, Aluminum (3)	BN38/39
25.	Spring (2)	BN38/344
27.	Washer, Aluminum (2)	BN38/172
28.	Spring, Low Speed	BN38/343
29b.	Adjuster, Low Speed	BN38/166
33.	Plate, Needle Valve Retainer	BN34/177-GG
34.	Screw with Washer	CW2-0307-G
37.	Screw	BV15/121-05-GG
38.	Plate, Valve	BN34/108-GG
39.	Valve Body Assembly	BN44/165
40.	Screw (2)	C5-0414-G
41.	Screw	C6-0308-G
42.	Cover (Stainless)	BN44/147
70.	Screw with 2 Washers (4)	BN34/120-35
73.	Stop Screw, Idle	BN38I/40
76.	Screw (4)	C2S=0514
77.	Diaphragm, Accelerator. Pump	BN40I/22
79.	Body Assembly, Pump	BN46I/49



ADJUSTER WITH CROSS BAR

This allows simple tuning adjustments, which is not possible with oem screw.

"I" series 44/46, OEM Yam GP800 & SD 951 Part No.
High Speed cross bar screw **SA-100**

OEM Yamaha Carb, XL1200LTD, XLT1200, GP1200R Part No.
Low Speed cross bar screw **SA-200**
High Speed cross bar screw **SA-300**

OEM Kawasaki Carb, Kawasaki 800SX-R Part No.
Low Speed cross bar screw **SA-500**
High Speed cross bar screw **SA-100**

OEM Yamaha Carb, Superjet 2004+ Part No.
Low Speed cross bar screw* **SA-700**
High Speed cross bar screw* **SA-800**

*Choke must be removed to install SA-700 and SA-800



SUPER BN 46 "I" TYPE CARB

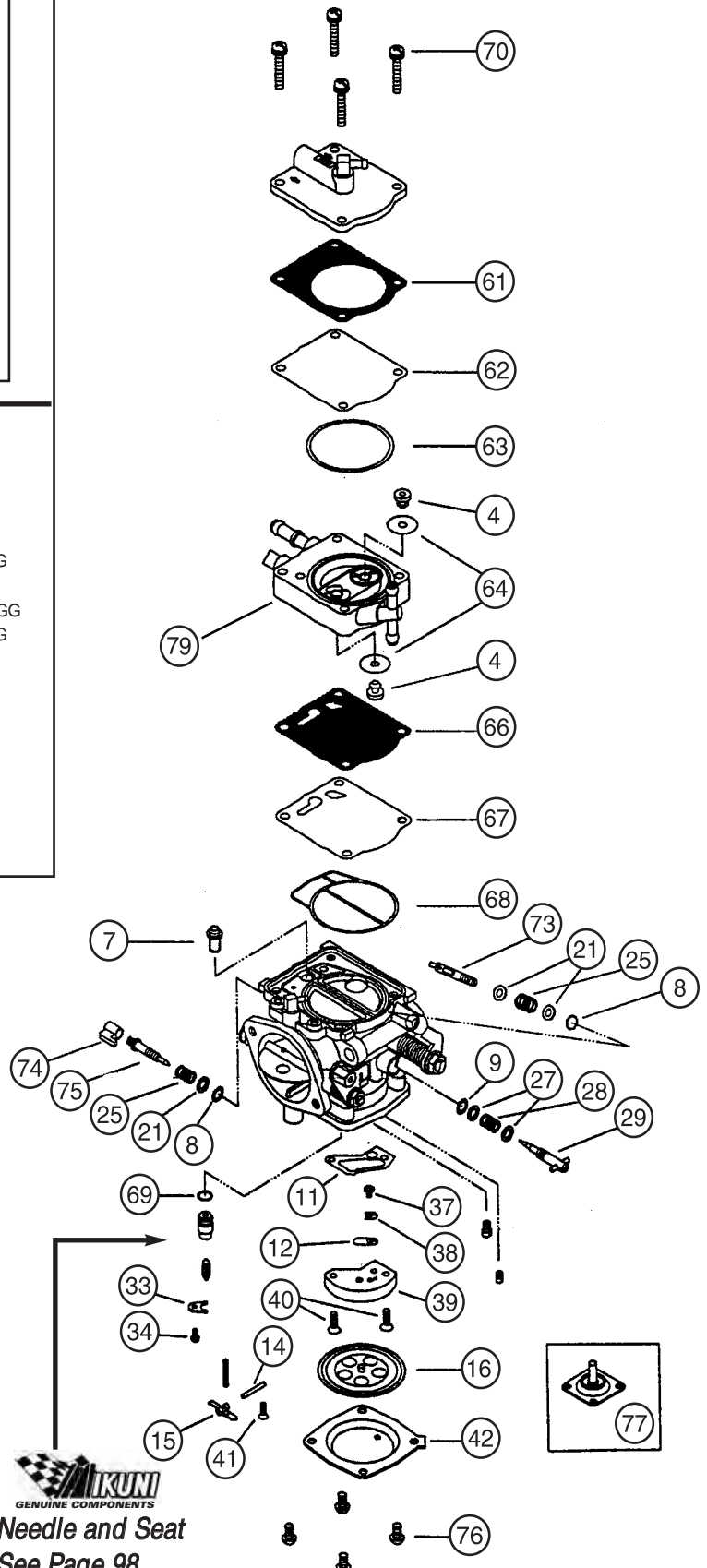

Needle and Seat
See Page 98

For Yamaha GPR Mikuni Carb Repair Kit, see page 100

FOUR STROKE
INTAKE SYSTEMS
ENGINE/GASKETS
EXHAUST
DRIVE LINE HANDLING
ELECTRICAL
WATERLINE /BILGE
STEERING & CONTROLS
BODY
ACCESSORIES SERVICE TOOLS
HARDWARE
CHEMICAL

SUPER BN 44I/46I FOR YAMAHA

Rebuild kit for one Super BN44I or BN 46I carburetor.

FITS ONLY: Yamaha Watercraft engine with Power Valve System (Type 60T, 66E, 66V, 67X, 68N)



- FOUR STROKE
- INTAKE SYSTEMS
- ENGINE/GASKETS
- EXHAUST
- DRIVE LINE HANDLING
- ELECTRICAL
- WATERLINE /BILGE
- STEERING & CONTROLS
- BODY
- SERVICE TOOLS ACCESSORIES /HARDWARE
- CHEMICAL

Diagram No.	Description	Mikuni Part No.
1.	Gasket, Pump	BN46I/13
2.	Diaphragm, Pump (Clear)	BN46I/14
3.	O-Ring	616-92014
4.	Check Valve (2 pcs)	999-815-071
5.	Grommet (2 pcs)	BN34/125
6.	Diaphragm, Damper	BN46I/34
7.	Diaphragm, Damper (clear)	BN46I/15
8.	O-Ring	616-92015
9.	Filter, Fuel	BN44/146
10.	O-Ring, High Speed	BN21/156
11.	O-Ring, Low Speed	BN21/156
12.	O-Ring, Needle Valve	KV/10
13.	Gasket, Valve Body	BN34/123
14.	Check Valve (clear)	BN34/107
15.	Pin, Arm	VM30/97
16.	Spring, Arm 115 gram	730-03027
17.	Arm (Stainless)	BN38/534
18.	Diaphragm Assembly, Main	BN44/145
39.	Screw	C6-0308-G

MK-BN 44I-YAM

SBN44I/SBN46I REPLACEMENT PARTS

19.	Screw with 2 Washers (4)**	BN34/120-35
20.	Cover, Pump	.Not Available
21.	Body Assembly, Pump	BN46I/49
22.	Stop Screw, Idle	BN38I/40
23.	Washer, Aluminum (3)	BN38/39
24.	Spring (2)	BN38/344
25.	Cap, High Speed Adjuster	.Not Available
26.	Adjuster, High Speed	604-25017
27.	Washer, Aluminum (2)	BN38/172
28.	Spring, Low Speed	BN38/343
29.	Adjuster, Low Speed	BN38/477
30.	Jet, High Speed	N102.221-size
31.	Jet, Low Speed	N100.606-size
32.	Screw	BV15/121-05-GG
33.	Plate, Valve	BN34/108-GG
34.	Valve, Body Assembly	BN44/165
35.	Screw (2)	C5-0414-G
36.	Needle Valve Assembly	SEE PAGE 98
37.	Plate, Needle Valve Retainer	BN34/117-GG
38.	Screw w/Washer	CW2-0307-G
39.	Screw	C6-0308-G
40.	Cover, (stainless, unpainted)	BN44/147
41.	Screw (4)**	C2S-0514
42.	Diaphragm, Accelerator Pump	BN40I/22

**Tightening Torque:
Part No. 19: 4.5 N•m (45 kg•cm)
Part No. 42: 3.5 N•m (35 kg•cm)

Note: DO NOT use gasket sealant during assembly.

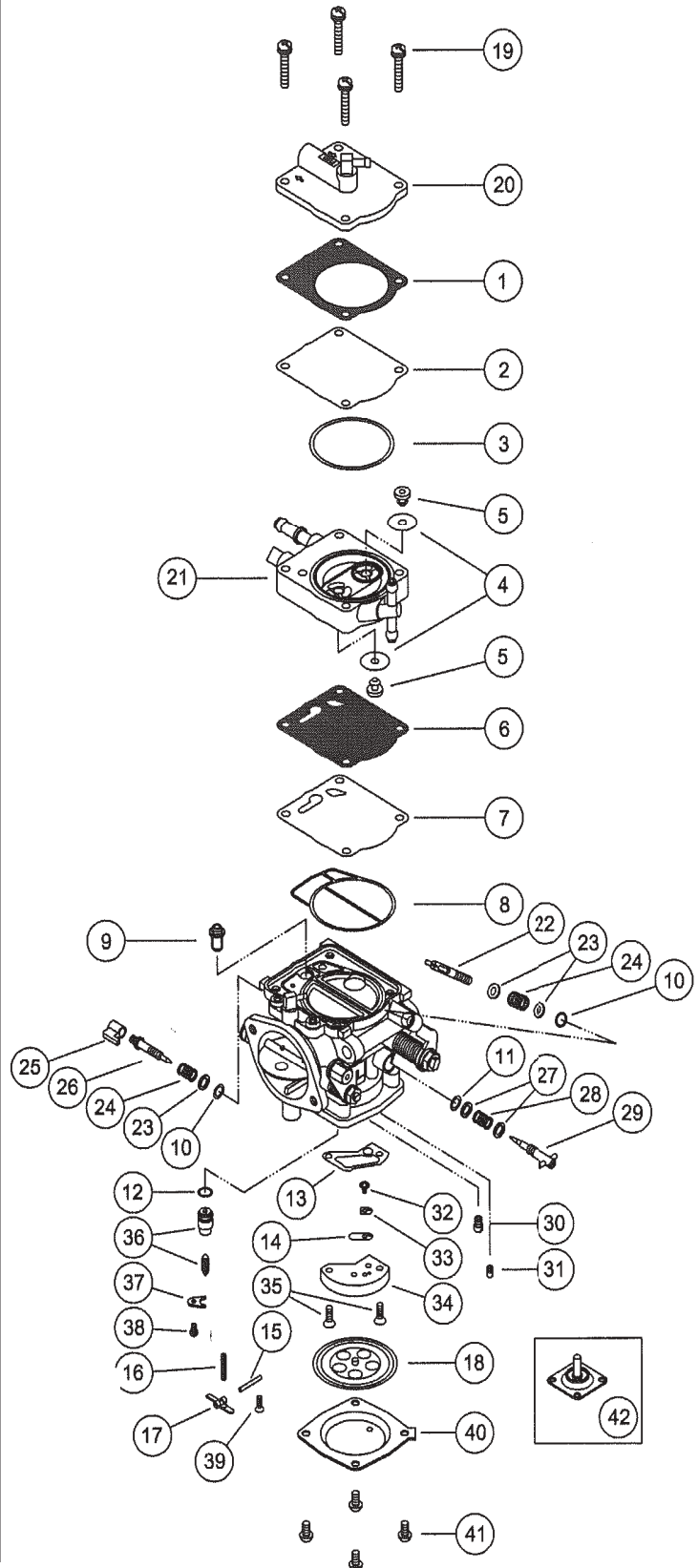



DF62-702

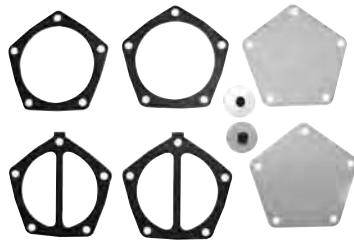

MK-DF62

MIKUNI HIGH VOLUME FUEL PUMP

16 gallons/61 Liters per hour

Description	Part No.
Mikuni Fuel Pump	DF62-702
Mikuni Fuel Pump Repair Kit	MK-DF62



M-VM40-200K

I-VM44-200-1

SPIGOT MOUNT FLANGE FOR MIKUNI CARBURETOR

For easier removal and installation of carburetor for jetting and maintenance. Recommended to use with side draft manifold only.

Description	Part No.
Spigot Mount Flange (Silver Band)	M-VM40-200K
Spigot Mount Flange Sea Doo 951 (Black Band)	I-VM44-200-1



**Fuel pump is not included

BLOWSION CARBON FIBER REMOTE FUEL PUMP BRACKET

Use this ultra sano 100% carbon fiber fuel pump bracket when adding remote fuel pumps. Lightweight and burly, this is the key to your mounting problems without adding weight or stress to the engine compartment.

Description	Part No.
Fuel Pump Bracket	01-02-556



MIKUNI FUEL PUMP BLOCK OFF

Block off plates sold individually, one block off plate only, no bolts are included with the block off plate. Sold each.

Description	Part No.
Mikuni Fuel Pump Block Off	BN34/126



BLOWSION FUEL PUMP BLOCK OFF

Blowson has created these sanitary anodized and engraved Blowson logo carb block offs. A necessity when using a remote fuel pump. Fits all Mikuni carbs. Billet aluminum and includes all stainless hardware.

Description	Part No.
Blowson Mikuni Fuel Pump Block Off	01-02-557

MIKUNI POP-OFF GAUGE

For Accurate adjustment of pop off pressure levels for fine tuning requirements.



Description	Part No.
Mikuni 30 lbs. Gauge	MK-BN PMP
Mikuni 60 lbs. Gauge	MK-BN PMP-60
Mikuni 100 lbs. Gauge	MK-BN PMP-100



MIKUNI POCKET TUNER

A handy pocket-size slide calculator which can be used to determine required jetting changes in Mikuni carburetors due to ambient temperature, altitude or both.

Description	Part No.
Mikuni Pocket Tuner	MK-550-TNR



MIKUNI TOOL KIT

This handy little kit contains all the tools necessary to make jetting change, perform normal maintenance as well as disassemble and rebuild any Mikuni carburetor.

Description	Part No.
Mikuni Tool Kit	MK-404

FOUR STROKE	INTAKE SYSTEMS	ENGINE/GASKETS	EXHAUST	DRIVE LINE HANDLING	ELECTRICAL	WATERLINE /BILGE	STEERING & CONTROLS	BODY	ACCESSORIES	SERVICE TOOLS /HARDWARE	CHEMICAL
-------------	----------------	----------------	---------	---------------------	------------	------------------	---------------------	------	-------------	-------------------------	----------

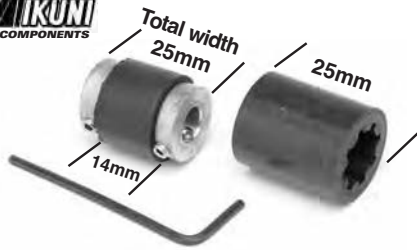

MIKUNI DUAL CARBURETORS LINKAGE KIT

The Mikuni Dual linkage kit includes all items as pictured: One complete linkage, one allen wrench and two dampers (14mm & 25mm) are included.

Description	Part No.
Mikuni Dual Linkage Kit	MK-BN/001



JETWORKS LINKAGE

Using 120mm center to center aftermarket dual S/BN carburetor applications. It is made to have zero backlashes and will not compress after age.

Description	Part No.
120mm center to center	LK-2



CARBURETORS LINKAGE

Linkage Kit	Part No.
Mikuni Carburetor Linkage	53-0622



MIKUNI GENUINE OEM STYLE LINKAGE RODS

Description	Part No.
D. Sea Doo XP800	BN38/573-1A
E. Sea Doo 951	BN38/573-1C



CARBURETORS LINKAGE SLEEVES

Sleeve Only		Part No.
3/4"	19mm	53-9906
1"	25mm	53-9916
2-3/16"	56mm	53-9917
6"	152mm	53-9918



JET WORKS 48MM BUTTERFLY

Description	Part No.
Jet Works 48mm Butterfly	48-012

**No butterfly screws are included.*

MISCELLANEOUS HARDWARE FOR CARBURETORS

All Items are Sold Individually



Description	Part No.
6m x 25mm Metric Stud	62-3025



Description	Part No.
6m x 50mm Metric Stud	63-3050



Description	Part No.
Press-in Nipple 1/4"-1/8"	53-9935



Description	Part No.
Throttle Linkage Arm	53-0610



Description	Part No.
Throttle Linkage Arm	53-0607

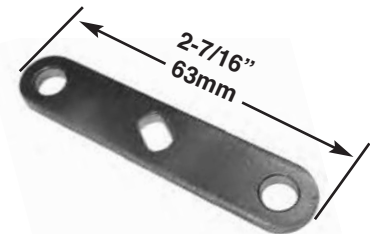

Description	Part No.
Throttle Linkage Arm	53-0608



Description	Part No.
Throttle Arm	53-0609



Description	Part No.
Plastic T Fitting 1/4"-1/4"-1/8"	64-0095
Brass T Fitting 1/4"-1/4"-1/8"	64-0017

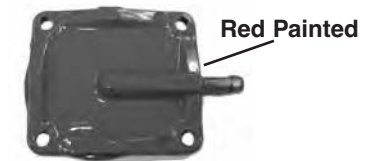

Description	Part No.
Mikuni Pump Side Cover - Red Color	BN 34/95B-Red



HOT PRODUCTS THROTTLE CABLE DRUM FOR MIKUNI

Hot Products original billet throttle drum for Mikuni carburetors allows the use of any throttle cable and bracket on Mikuni carburetors. 9 positions, 18mm throw. Anodized black.

Description	Part No.
Hot Products Cable Drum 18mm Throw	53-2622

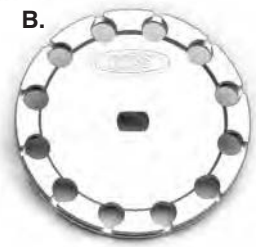
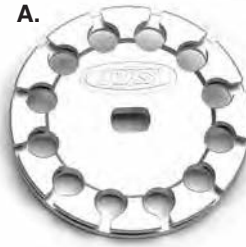

PJS THROTTLE CABLE DRUM FOR MIKUNI

PJS Drums features a center web thin enough to allow use of nut with lock washer. "D" slot match the throttle shaft for a perfect fit. 12 positions and available in 20mm or 25mm throws, anodized clear.

Description	Part No.
A. Standard Size (20mm throw)	CB-00200
B. Oversized (25mm throw) For Oil injection and stock carburetors of Yamaha GP/XL	CB-00205



8mm

PJS DIAPHRAGM COVER MOUNT THROTTLE CABLE BRACKET

Recommended for use with Hot Products Cable Drum Part #53-2622. Hardware included.

10mm



PUMP MOUNT THROTTLE CABLE BRACKET

Recommended for use with Hot Products Cable Drum Part #53-2622. Hardware is not included.

Description	Cable Size	Part No.
Universal Throttle Cable Bracket	8mm	CB-00210

Description	Cable Size	Part No.
Cable Mount Diameter	10mm	53-3317



MOTOINE SOFT SPRING FOR MIKUNI CARBS

New Motoine Mikuni spring is 2/3 softer than original spring and reduces thumb and/or finger throttle fatigue.

Description	Part No.
Motoine Soft Spring	MR-00013



ADA RACING CABLE BRACKET FOR OEM CARBS

Kawasaki 750/800 throttle cable/choke cable bracket. For use with stock carbs when using the ADA Racing billet girdle head kit. This bracket has the throttle cable mount moved up, so it does not interfere with the girdle bracket.

Description	Part No.
ADA Bracket	KA800BRK-CARB



2012 HOT PRODUCTS SPONSORED RACER
TAYLOR CURTIS • FREERIDE
PHOTO COURTESY OF YUSUKE IMAIZUMI

FOUR STROKE	INTAKE SYSTEMS	ENGINE/GASKETS	EXHAUST	DRIVE LINE HANDLING	ELECTRICAL	WATERLINE /BILGE	STEERING & CONTROLS	BODY	ACCESSORIES	SERVICE TOOLS /HARDWARE	CHEMICAL
-------------	----------------	----------------	---------	---------------------	------------	------------------	---------------------	------	-------------	-------------------------	----------

KEIHIN GENUINE CARBURETOR REBUILD KITS

Kits include all necessary gaskets, diaphragms, and hardware required to rebuild Keihin carburetors.



Description **Part No.**
38/40mm OEM Type & 42mm CDKII 53-2103

POLARIS • Hurricane 700 96-97, SL/SLT 700 96-97, SLH 700 96-97, SL900 96-97, SL/SLTX 1050 96-00, SLXH 1050 98-99, Genesis 99-00, 1200Pro 00, Virage/TX 00

KAWASAKI • JS440 91-92, JS550SX 91-95, 650TS 89-96, 650SC 90-95, 750SX 92-95, 750SXI 95, 750SS 92-98, 750XI 93-97, 750XIR 94, 750ST 94-95, 750STS 95-97, 750ZXI 95-98, 900ZXI 95-97, 900STX 97-99, 1100ZXI 96-97



Description **Part No.**
28mm OEM Type 53-2100

KAWASAKI • J650 SX 1986-91 & 650 X-2 1986-91



KEIHIN FUEL PUMP REBUILD KIT

Includes all parts necessary to rebuild the Keihin fuel pump. Fits Kawasaki 650SX 1986-91, 650X2 1989-91.

Description **Part No.**
Keihin Fuel Pump Rebuild Kit 53-2105



MIKUNI SBN CARBURETOR ADAPTERS FOR KEIHIN INTAKE MANIFOLDS

This adapter allows you to run a Mikuni SBN 44mm or 46mm carburetor on your Keihin intake manifold.

Note: You MUST bore your intake to match the new larger carburetor size.

Description **Part No.**
Watcon Keihin Mikuni Intake Manifold Adapter ADPT-K



KEIHIN CARBURETOR ADAPTERS FOR MIKUNI CARBURETOR MANIFOLDS

Description **Part No.**
A. This adapter allows mounting of Keihin CDKII 38, 42 carburetor to any popular O.E. or aftermarket 44mm Mikuni intake manifold. 53-3305

**The carb will stand straight up when using this adapter - the carb is just rotated a few degrees to clear the adapter mounting bolts.*

**A short air filter is required for to prevent rubbing on the inside of the hood*

Description **Part No.**
B. This adapter is designed to mount to the Keihin CDKII 38, 42 carburetor at an angle specifically for the Kawasaki JS440/550 piston port engine. 53-3308

**A short air filter is required for to prevent rubbing on the inside of the hood*



CARBURETOR JETS

Keihin Low Jets		Keihin Main Jets	Keihin Main Jets	
P/# (N424-35-size)	P/# (N424-27-size)		P/# (N424-36-size)	
40	88	150	100	150
42	90	155	102	152
45	92	160	105	155
48	95	165	108	158
50	98	170	110	160
52	100	175	112	162
55	102	180	115	165
58	105	185	118	168
60	108	190	120	170
62	110	195	125	172
65	112	200	128	175
68	115	(for CDCV)	130	178
70	118		132	180
72	120		135	182
75			138	185
78			140	190
80			142	195
85			145	200
			148	

**GENUINE KEIHIN
CARBURETOR PARTS**



Description	Diagram	Keihin Part No.
Screw	102	N114-03060
Adjust Screw (Main)	103	DISCONTINUED
Adjust Screw (Slow)	107	Z014-0670
Check Valve	110	1242-809-2000
Gasket	111	1202-823-2000
Cover	113	1230-827-2000
Diaphragm	114	1201-813-2100
Screw	115	93500-04008-1H
Arm Spring	116 A	1290-966-2000
Arm Spring	116 B	1290-947-2000
Screw	117	4114-001-1200
Arm Pin	118	16152-KG8-9010M1
Float Arm	119	DISCONTINUED
Needle Valve	120	1062-818-2000
Gasket	121	1202-822-2000
U-Ring	123	0903-809-6000
Lever Pin	126	DISCONTINUED
O-Ring	128	0901-055-6000
Screen	130	2009-811-2100
Diaphragm	134	1201-825-2000
O-Ring	137	0901-841-6000
Gasket	139	1202-851-2000

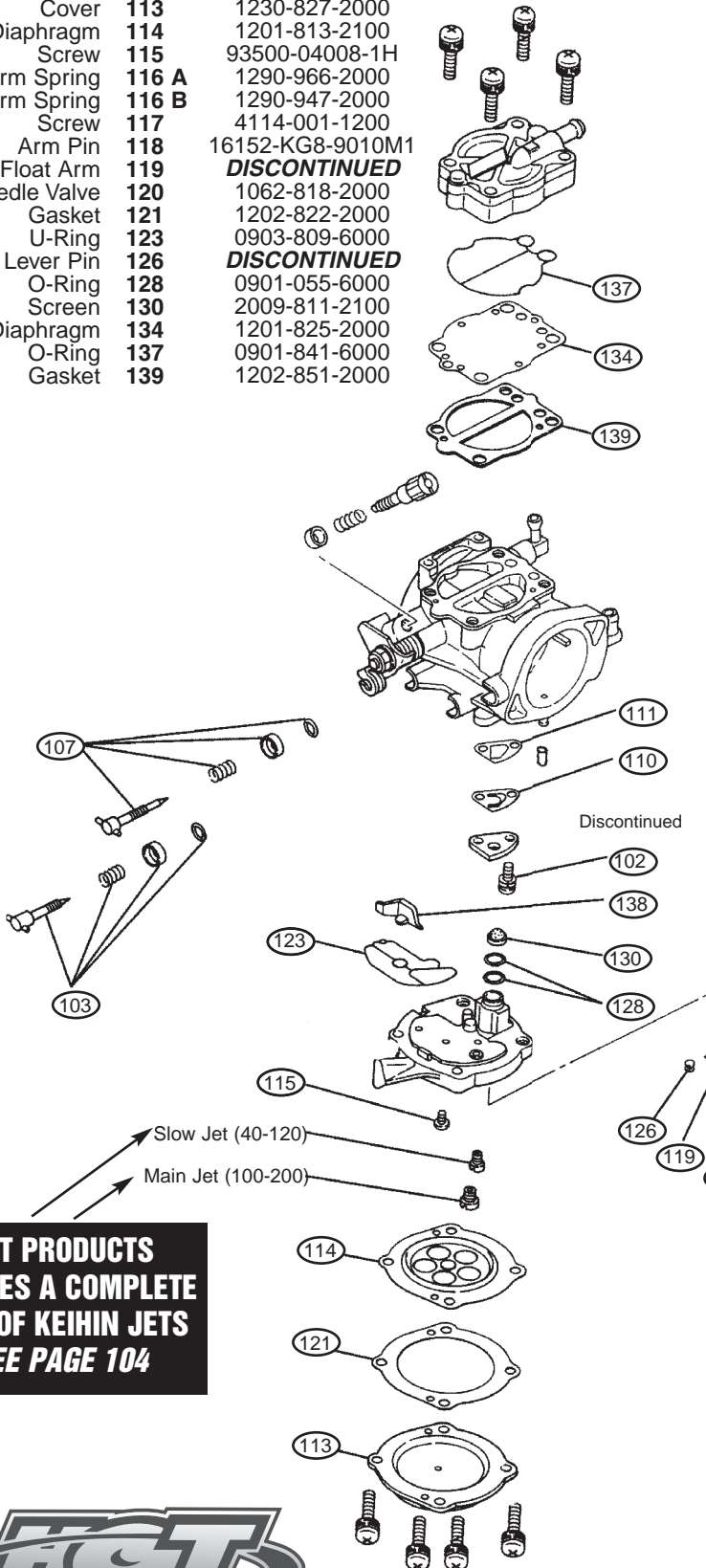

**HOT PRODUCTS
CARRIES A COMPLETE
LINE OF KEIHIN JETS
SEE PAGE 104**

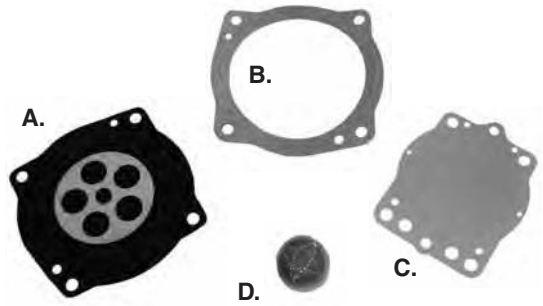

KEIHIN DIAPHRAGM & FILTER

Description	Part No.
A. Diaphragm Assembly	1201-813-2100
B. Gasket	1202-822-2000
C. Diaphragm	1201-825-2000
D. Screen Filter	2009-811-2100



CARB SCREW ADJUSTING TOOL

A special 90-degree screwdriver, designed to adjust carburetors of triple-cylinder watercraft.

Description	Part No.
Carb Screw Adjusting Tool	08-0119

KEIHIN ARM SPRINGS

Description	Part No.
42mm 40 gram	1290-966-2000
42mm 70 gram	1290-947-2000
40mm 40 gram	1290-992-2000
40mm 70 gram	1290-961-2000



**ULTIMATE KEIHIN
CARB GASKETS**

Thick "Green" gaskets for Keihin carbs.

Description	Part No.
38mm	9200
40mm	9205
42mm	9220

FOUR STROKE
INTAKE SYSTEMS
ENGINE/GASKETS
EXHAUST
DRIVE LINE HANDLING
ELECTRICAL
WATERLINE /BILGE
STEERING & CONTROLS
BODY
ACCESSORIES
SERVICE TOOLS /HARDWARE
CHEMICAL

SINGLE INTAKE MANIFOLDS FOR MIKUNI CARBURETORS



Includes Moto Tassanari V-Force 2 Reed. Made of billet aluminum, this single intake manifold will fit on Y701/760 cylinder.

Yamaha Part No.
DASA Billet Single Manifold Kit **IN-7003**



Includes carburetor mounting studs, nuts and gaskets.

Kawasaki Part No.
650 All **53-0651**



Includes carburetor mounting studs and nuts.

Kawasaki Part No.
750 All **53-0827**

DUAL INTAKE MANIFOLDS FOR MIKUNI CARBURETORS



R&D 800 SXR INTAKE MANIFOLD KIT

Kawasaki Part No.
800SX-R with Billet Carb. Plate for OEM Reed (Center to center 120mm) **231-75146**
**Note: This manifold is compatible with Moto Tassanari V-Force 3 Reed Sets based on the Reed Kit is supplied with stuffers that match perfectly to this R&D Manifold intake manifold.*
Mounting Plate Gasket **12-0010**



R&D SUPERJET INTAKE MANIFOLD KIT

Yamaha Part No.
701(62T) W/Rdr/760 With Billet Carb. Plate for **OEM Reed** (Center to Center 120 mm) **222-76000**
**Note: This manifold is compatible with Moto Tassanari V-Force 3 Reed Sets based on the Reed Kit is supplied with stuffers that match perfectly to this R&D Manifold intake manifold.*
Mounting Plate Gasket **12-0010**



Yamaha Part No.
Y701 (62T), Wave Raider/760 **13-2109**



Sea Doo Part No.
580/650/720 **53-0923**



Sea Doo Part No.
XP800 Direct Flow **223-80001**

TRIPLE INTAKE MANIFOLDS FOR MIKUNI CARBURETORS



KOMMANDER KAWASAKI 1100/1200 TRIPLE INTAKE MANIFOLD

Fits all 1100 Triple motors. Designed to fit all 44mm through 49mm Mikuni carbs. Supplied with all required hardware and gaskets.

Kawasaki Part No.
Kommander 1100/1200 Intake Manifold **KOM-107**



R&D YAMAHA 1100 TRIPLE INTAKE MANIFOLD

Fits all 1100 Triple motors. Designed to fit all 44mm and 46mm Mikuni carbs. Supplied with all required hardware and gaskets.

Yamaha Part No.
R&D 1100/1200 (63M/65U) Intake Manifold **232-11000**

DUAL INTAKE MANIFOLDS KITS FOR MIKUNI CARBURETORS

IMK-001



BOYESEN EXTREME VELOCITY SUPERJET INTAKE KIT & RAD VALVES

Yamaha	Part No.
701 Superjet 96-08, Extreme Velocity Intake Kit*	IM-001KIT
Extreme Velocity Intake Manifold Only	IM-001
"EV" RAD Valves Kit (2 Valves per Kit)	RAD-131A
Replacement RAD Reed for RAD-131A	PSR-131A
IMK-001 Intake Manifold/Reed Gasket Only	IMG-001

*Kit includes (1) precision cast aluminum intake manifold, (2) "EV" RAD valves, (1) carb adapter plate and all necessary installation hardware.



IMK-002

BOYESEN EXTREME VELOCITY 800 SXR INTAKE KIT & RAD VALVES

Kawasaki	Part No.
800SX-R 03-08, Extreme Velocity Intake Kit*	IM-002KIT
Extreme Velocity Intake Manifold Only	IM-002
"EV" RAD Valves Kit (Single Valve)	RAD-113
Replacement RAD Reed for RAD-113	PSR-131A
IMK-001 Intake Manifold/Reed Gasket Only	IMG-002

*Kit includes (1) precision cast aluminum intake manifold, (2) "EV" RAD valves, (1) carb adapter plate and all necessary installation hardware.



DASA BILLET ALUMINUM DUAL YAMAHA INTAKE MANIFOLD KIT

Designed by the billet masters at DASA, this 6061 billet Dual intake manifold incorporates a "tipped or directional" reed design without the need of a spacer plate. What this results in is a boost in overall hp without a significant loss in low speed performance. Hardware included to fit 62T cases. Supplied with VForce 2 Reed Kit.

Yamaha	Part No.
DASA Billet Dual Intake Manifold Kit	IN-7001

Yamaha Crankcase Application Chart

6M6 650LX, VXR, Wave Runner III, Super Jet 90-93	63M Raider 1100, Venture 1100
61X Pro VXR, Wave Runner III, GP, Super Jet 94-95, Fx-1, Wave Blaster 93-95, Raider 701 96-97	66E GP800 Power Valve
62T Super Jet 96-01, Blaster II	65U GP1200, XL1200, SUV1200
64X Wave Blaster 96-97, GP760, Raider 701/Deluxe/760 94-95, Venture 701/760, XL700/760	66V GP1200R, XL1200 LTD/XLT, 99-01 Power Valve



WATCON 550 INTAKE MANIFOLD SPACER

This Watcon intake spacer will allow the proper clearance for the SBN 44/46mm carb to be installed on a JS440/550 stock intake manifold.

****Gaskets and Hardware not included.**

Kawasaki	Part No.
Watcon Intake Man. Spacer	K550-SPCR
Intake Manifold Gasket	5250



For Mikuni SBN 44, 46 or 48mm Spigot Mount Carb Applications

Kawasaki	Part No.
Ultra 150/STX-R Kit	231-15000
*Use with M-16 reed only	



Yamaha	Part No.
GP800 with stuffers	222-80000

FOUR STROKE
INTAKE SYSTEMS
ENGINE/GASKETS
EXHAUST
DRIVE LINE HANDLING
ELECTRICAL
WATERLINE /BILGE
STEERING & CONTROLS
BODY
ACCESSORIES
SERVICE TOOLS /HARDWARE
CHEMICAL



Sea Doo	Carb	Flame Arrestor	Part No.
720	Mikuni 44mm	K&N	53-0915
720	Mikuni 46mm	K&N	53-0916

720 Kits also fit 650 & 580 Engines. Please specify for proper jetting.

All carburetor kits are assembled with the above listed K&N Filters or Tau Ceti Pro Series Flame Arrestors, the filter size and shape is the best fit based on the watercraft model.



HOT PRODUCTS YAMAHA AND KAWASAKI DUAL MIKUNI CARBURETOR KITS

Yamaha	Carb	Flame Arrestor	Part No.
701 W/Rdr / 760 (62T)	Mikuni 44mm	Tau Ceti	53-0975
701 W/Rdr / 760 (62T)	Mikuni 46mm	Tau Ceti	53-0974
1100/1200	Mikuni 44mm	Tau Ceti	53-0980
1100/1200	Mikuni 46mm	Tau Ceti	53-0992

Kawasaki	Carb	Flame Arrestor	Part No.
750	Mikuni 44mm	Tau Ceti	53-0830
750	Mikuni 46mm	Tau Ceti	53-0840

* See page 64 for crankcase application chart

All carburetor kits are assembled with the above listed Tau Ceti Pro Series Flame Arrestors, the filter size and shape is the best fit based on the watercraft model.

HOT PRODUCTS KAWASAKI SINGLE MIKUNI CARBURETOR KITS

Kawasaki	Carb	Flame Arrestor	Part No.
750 All	Mikuni 44mm	Tau Ceti	53-0820
750 All	Mikuni 46mm	Tau Ceti	53-0825

All carburetor kits are assembled with the above listed Tau Ceti Pro Series Flame Arrestors, the filter size and shape is the best fit based on the watercraft model.





ADA RACING ANGLED REED SPACER KIT

The ADA Racing Reed Spacer Kit features a 3 degree angle for Kawasaki engines. The kit includes billet aluminum spacers, gaskets, studs and additional pulse fittings.

Kawasaki	Part No.
A. Kawasaki 750/800 Angled Reed Spacer Kit	31-130390
B. Kawasaki 900/1100 Angled Reed Spacer Kit	31-131390



*Hardware not included.

R&D REED VALVE SPACERS

Kawasaki	Part No.
750/800 Reed Spacer Set	251-75010
750/800 Reed Spacer Angled Set	251-80000
Reed Gasket (sold individually)	7050
6x50mm Stainless Steel Studs (sold individually)	62-3050

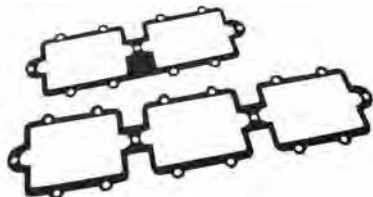

RIVA RACING REED VALVE SPACER GASKETS

Yamaha	Part No.
701/760 Spacer Gasket	53-5235-GSK
1100/1200 Spacer Gasket	53-5236-GSK



R&D REED VALVE SPACERS

Yamaha	Part No.
701/760 (62T/64X) Reed Spacer Angled	262-70101



PLASTIC CAPS

The plastic caps have many uses on a PWC. Use the caps to cap the primer fittings, fuel fittings and any other item you need to cap will performing repairs or performing routine maintenance. Caps are sold in packs of 10.

Description	Part No.
Small 1/8" Cap - Oil Primer Nipple (10 pack)	50-9500P
Large 3/8" Cap - Carb/Fuel Nipple (10 pack)	50-9504P



KAWASAKI DRAIN CASE BLOCK OFF

Kawasaki	Part No.
650/750 Kawasaki Drain Case Block Off	50-9505

**Case Block Off not applicable for 800SX-R*



BILLET ALUMINUM OIL INJECTION BLOCK OFF KITS



Sea Doo	Part No.
580/650/720 All	50-9504



Sea Doo	Part No.
800/951	50-9506



Polaris	Part No.
SL700/SLT700/Hurricane SL900/SLTX/1050	50-9509



Yamaha	Part No.
650/701/760	50-9500



Yamaha	Part No.
1100/1200 GPR	50-9501

Kawasaki	Part No.
650/750	50-9500

Kawasaki	Part No.
900/1100	50-9501

FOUR
STROKE

INTAKE
SYSTEMS

ENGINE/
GASKETS

EXHAUST

DRIVE LINE
HANDLING

ELECTRICAL

WATERLINE
/BILGE

STEERING
& CONTROLS

BODY

ACCESSORIES
SERVICE TOOLS

/HARDWARE

CHEMICAL

BLOWSION**BLOWSION****BLOWSION**

BLOWSION FUEL FILLER FOR YAMAHA SUPERJET AND POLARIS OCTANE

Description	Part No.
Billet Dual Pick Up	01-02-502
Billet Single Pick Up	01-02-501



BLOWSION FUEL FILLER FOR KAWASAKI SX/SXI/SXI-PRO/SX-R

Description	Part No.
Billet Dual Pick Up	01-02-506



BLOWSION RACING FUEL PICKUP FOR KAWASAKI SX/SXI/SXI-PRO/SX-R

Description	Part No.
Billet Dual Pick Up	01-02-507



FUEL PICKUP FOR 1100 SXR CONVERSION & ZXI/STX-R

Provides maximum fuel flow to triple carbs applications. Used by the top Professional Racers for conversion Race Ski applications.

Description	Part No.
Kaw 1100 SXR/ZXI/STX-R Fuel Pickup	53-9957



ONE WAY CHECK VALVE

One way vent valve allows air to travel in one direction only. 1/4" Fuel Line.

Description	Color	Part No.
A. One Way Check Valve 1/4" Hose Barb	Red	53-9941
B. One Way Check Valve 1/4" Hose Barb	Blk/Wht	CV-14B

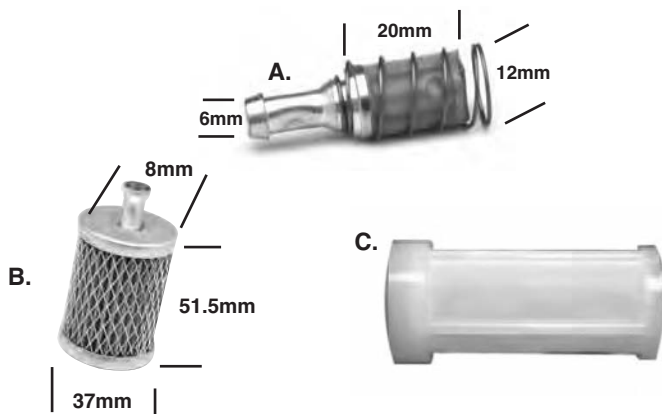

FUEL TANK FILTER

Description	Part No.
A. Universal Fuel Tank Filter (Replaces Sea Doo #275-500-005)	53-9946
B. Universal Fuel Tank Filter (Replaces Yamaha #8H5-224560-00)	006-516
C. Sea Doo Fuel Filter Tank Filter (Replaces Sea Doo #275-500-089)	006-510



R&D ULTRA 250X DEEP FUEL PICKUP

The R&D Deep Fuel Pickup is designed to maximize fuel volume. The stock fuel pickup is located horizontally in the gas tank three inches above the bottom of the tank. This leaves approximately 5 gallons of unusable fuel in the bottom of the tank. The R&D Deep Fuel Pickup relocates the stock fuel pickup to the bottom of the tank in a vertical position. The new positioning allows for 24 percent more riding time per tank of gas. The deep fuel pickup is an absolute must for offshore racing.

Description	Part No.
R&D Ultra 250X/LX Deep Fuel Pick Up	801-25100



RIVA HIGH VOLUME FUEL FILTER

3/8" Fuel Line.

Description	Part No.
3/8" RIVA High Volume Filter	RY0503



2" SLIMLINE FUEL FILTER WITH BRONZE ELEMENT

Clear nylon housing and bronze 75 Micron Element. 2" length. 1/4" Fuel Line.

Description	Part No.
2" Slimline with bronze	53-9952
Retail sales display card with 20 filters	53-9952D



3" SLIMLINE FUEL FILTER WITH POLYESTER ELEMENT

Lightweight high flow 90 Micron Polyester Element. 3" length. 1/4" Fuel Line.

Description	Part No.
3" Slimline with polyester	53-9953
Retail sales display card with 20 filters	53-9953D



HOT PRODUCTS IN-LINE OIL FILTER

75 Micron Stainless Steel Element. 1.3" diameter, 1/4" Fuel Line. This filter works with fuel and oils. Perfect protection for oil pumps and oil injection engines.

Description	Part No.
Stainless Steel Filter	53-9943
Retail sales display card with 20 filters	53-9943D



HIGH-CAPACITY HIGH FLOW FUEL FILTER

80 Micron Paper Element. 1.6" diameter, 1/4" Fuel Line.

Description	Part No.
High Flow Paper Filter	53-9945
Retail sales display card with 20 filters	53-9945D



RIVA OE REPLACEMENT FUEL FILTERS

OE replacements fit stock mounting bracket in all Yamaha watercraft these fuel filters also serve as a water separator protecting the motor from water damage

Description	Part No.
OE Replacement Filter (all except 66V/E)	RY-0501
OE Replacement Filter 66V/E	RY-0502



Recommended Main Jets:

Stock Carbs for 1200 (66V) 105
 Novi Carbs for 1200 (66V) 100-120
 Novi Carbs for 701 (61X) 100-120

RIVA FUEL RETURN LINE RESTRICTOR 1/4" LINE

Designed to improve throttle response and reduce lean conditions in power band, the RIVA Fuel Return Line Restrictor installs into fuel return line between carburetors and fuel tank, restricting fuel return rate, increasing pressure to carburetors. Precision-machined billet restrictor is threaded to accept a Mikuni Main Jet (not included) to match your application. For use with OEM and aftermarket carburetors.



QUICK DISCONNECT RESTRICTOR

Mikuni main jets thread into the billet part of the restrictor. This kit is used on the return lines of carburetors to fine tune fuel pump pressures.

Description	Part No.
Quick Disconnect Restrictor 1/4"	QD-14

Description	Part No.
Fuel Return Line Restrictor	RY12-RLR-14



2011 ALPE ADRIA CUP JUNIOR CLASS

HOT PRODUCTS PRIMER KITS



53-9920 - Single Mikuni Primer Kit Shown

A cure for hard-starting motors. Draws fuel from the fuel line to give the carburetor a blast of fuel for easy starting. Eliminates chokes and adds to battery life. A must on high-performance modified carburetors with eliminated chokes. Hot Products primers are assembled with top-quality materials and include 9 feet of 1/8" blue primer hose to fit sit down craft. USA made top-quality plunger, brass "T" fittings, spigot, caps and zip ties.

Plunger Primer Kit		Part No.
Mikuni Primer Kit	Single	53-9920
Mikuni Primer Kit	Dual	53-9928
Mikuni Primer Kit	Triple	53-9922
Keihin Primer Kit	Single	53-9925
Keihin Primer Kit	Dual	53-9929
Keihin Primer Kit	Triple	53-9924

HOT PRODUCTS PRIMER KIT BREAKDOWN BY PART NUMBER AND QUANTITY PER ITEM

Primer Kit Part No.	Item Description Item Part No.	Plunger Primer 53-9910A	Primer Line 53-9980	1/4x1/4x1/8 "T" 64-0017	1/8x1/8x1/8 "T" 64-0015	Mikuni Fittings 53-9921	Keihin Fittings 53-9926	Zip Ties See Pg. 234
53-9920	MIKUNI SINGLE	1	9FT	1	0	1	0	3
53-9928	MIKUNI DUAL	1	9FT	1	1	2	0	6
53-9922	MIKUNI TRIPLE	1	9FT	1	2	3	0	6
53-9925	KEIHIN SINGLE	1	9FT	1	0	0	1	3
53-9929	KEIHIN DUAL	1	9FT	1	1	0	2	6
53-9924	KEIHIN TRIPLE	1	9FT	1	2	0	3	6

HOT PRODUCTS PRIMER KIT REPAIR PARTS



53-9915 Button Primer



53-9910A Plunger Primer



Spigot & Plug Kit

Brass T Fitting

Primer Kit Parts Only	Part No.
G. Mikuni Brass Spigot & Plug Kit	53-9921
Mikuni Brass Plug Only	53-9921B
H. Keihin Brass Spigot & Plug Kit	53-9926
Keihin Brass Plug Only	53-9926B
I. Brass T for Dual 1/8 x 1/8 x 1/8	64-0015
J. Brass T for Primer 1/4 x 1/4 x 1/8	64-0017
Primer Line 1/8" (Sold per foot) <i>Color Blue</i>	53-9980

Primer Kit Parts Only	Part No.
Plunger Primer Only	53-9910A
Button Primer Only	53-9915

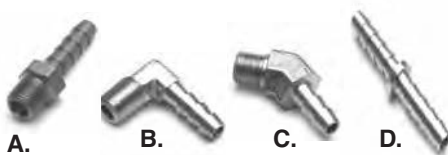

1/4" HOSE BRASS FITTINGS

Description	Part No.
A. Straight: 1/8" Thread 1/4" Hose	64-0001
B. 90 Deg: 1/8" Thread 1/4" Hose	64-0010
C. 45 Deg: 1/8" Thread 1/4" Hose	64-0065
D. Barb Connector 1/4" I.D.-1/4" I.D.	64-0057



PRESS IN NIPPLE

Description	Part No.
1/8" Straight	53-9936
1/4" Straight	53-9937



PLASTIC "Y" FITTINGS

Description	Part No.
1/4" X 1/4" X 1/4" (White)	64-0046
1/4" X 1/4" X 1/4" (Black)*	64-0047

*Reinforced with Crossbar



1/4" FUEL LINE & 1/8" PRIMER LINE

Our fuel and primer line is made from a thick walled polyurethane tubing. Both the fuel and primer line is clear blue. Sold per foot or 25 feet packages.

Description	Part No.
Fuel (1/4") per foot	53-9970
Fuel (1/4") - 25 foot package	53-9970-25
Primer Line (1/8") per foot	53-9980
Primer Line (1/8") per foot - 25 foot package	53-9980-25



FUEL LINE Q/D W/SHUT-OFF VALVE for 1/4" fuel line

Description	Part No.
Fuel Line Q/D w/Shut-off Valve	53-9951



HOSE PINCHER

Clamps and holds hoses up to 3/4" inside diameter. Angled jaws close to create a complete seal every time. Jaws are offset for hard-to-reach areas. The handles lock firmly to hold the jaws in closed position.

Description	Part No.
Hose Pinchers	LS23000



MOTION PRO LOW PERMEATION PREMIUM FUEL LINE

Motion Pro's new "low permeation" fuel line meets the 2008 C.A.R.B. and EPA fuel line permeation standards for PWC's, ATV's, motorcycles, Snowmobiles and small engines.

- Gray color
- Available in 1/4" ID
- Flexible and kink resistant

Description	Part No.
Fuel Line 1/4" (6mm) ID, 3/8" (10mm) OD, 25' rolls	12-0068

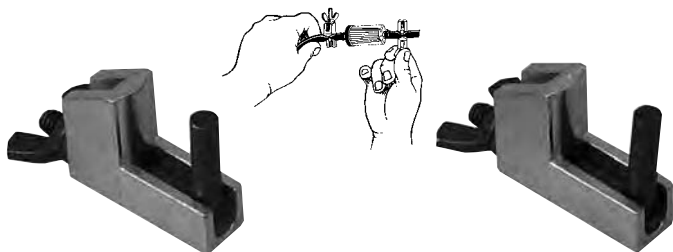

HOSE PINCHERS

Quick, easy way to pinch off fuel lines, etc, without damaging the fuel line. Sold two per set.

Description	Part No.
Hose Pinchers	LS22850



HOSE SHEARS

Simply Scissor-action cutter for hose. Cuts clean, straight and no damaged hose ends. A must have tool for every toolbox.

Description	Part No.
Hose Shears	12-0013

Fast, Easy, Strong and Secure Installation



Pincer Tool Part # 12-0024

SQUEEZE ON STAINLESS STEEL LOW PROFILE CLAMPS

Oetiker Stepless Ear Clamps, due to the reinforcing 'dimple' in the ear, hold against pressure and vibration or hose shrinkage due to temperature changes. A built-in spring action permits the clamp to "breathe" without loosening, the need to retighten is eliminated. Once installed,

Fast & Easy Removal

any tampering is easily visible, making this an excellent clamp for service or security applications.

Description	Clamp Size	Part No.
Pincer Tool	-	12-0024
Clamp for 1/4" Fuel Line Hose (10/pack)	-	59-4014
Clamp for 1/4" Fuel Injector Hose (10/pack)	9/16	59-4016
Clamp for 3/8" Water Line (10/pack)	11/16	59-4017
Clamp for 1/2" Water Line (10/pack)	13/16	59-4018

100 Clamp Packs	Clamp Size	Part No.
Clamp for 1/4" Fuel Line Hose (100/pack)	-	59-4014-100
Clamp for 1/4" Fuel Injector Hose (100/pack)	9/16	59-4016-100
Clamp for 3/8" Water Line (100/pack)	11/16	59-4017-100
Clamp for 1/2" Water Line (100/pack)	13/16	59-4018-100



Carbon Tech



Sea Doo

CC	Model	Year	Performance Info	Part No.
951	All 951 models	97-06	Better mid & tpend for stock, limited and superstock motors: +4hp midrange,+2 top 206HT Highly modified motors for topend only	206SS or 206HT

Yamaha

CC	Model	Year	Performance Info	Part No.
650	All 650 models	89-96	Smoother powerband	223LT
701	Wave blaster	93-95	225LT Stock cylinder, single carb.	225LT
with	Superjet	94-95		
61X	FXI	94-95	225M Ported motors, single carb. 225SS Ported motors, dual carbs	or 225M 225SS
CASE	PROVXR	93-94		
	Waverunner III	94-95,97		
	Waveraider	96-97		
701	Waveraider	94-95	202LT +3HP in midrange: for limited and stock motors	202LT
with	Waveblaster	96		
62T	Superjet	96-09		
CASE	Wave Venture	95-98		
	XL 700	99-04		
760	All 760 Models	96-00	202LT +3 HP in mid, +2HP top end for limited and non-ported rec boats	202LT
800	GP800	98-00	Better midrange & topend for stock	266HT
	GP800R	01-05	Limited & superstock motors: Gives 100 RPM=1 MPH	
	XL/XLT 800	00-04	(tested by Pro-Tec)	
1100	All 1100 models	95-97	Better midrange	302LT
1131	GP1200	97-99	*+3 HP mid to top: limited racing	338LT
	XL1200	98-99	Top end: only choice for fuel Ing.	338HT
	SUV1200	99-04		
1176	XL1200ltd	99-00	Stock motors, single pipe motors	366HT
	XLT1200	01-05	Single pipe, limited triple pipe	366SS
	GP1200R	00-02		
1296	GP1300R	03-08	Stock motors, single pipe motors	366HT
			Single pipe, limited triple pipe	366SS

Kawasaki

CC	Model	Year	Performance Info	Part No.
550	ALL 550	91-95	Smoother powerband	239LT
650	ALL 650	86-96	Improved low to midrange	212LT
743	ALL 750	92-02	Better low & mid: stock & limiteds	238LT
			Superstock & ported motors	238SS
			High RPM, stroked or fuel injected	238HT
782	800 Motor	03-09	Better low & mid: stock & limiteds	238LT
			Superstock & ported motors	238SS
			High RPM stroked or fuel injected	238HT
891	ALL 900 MOTORS	95-06	Better midrange and bottom end	338LT
1071	ALL 1100 MOTORS	96-04	Better low & mid: stock & limiteds	338LT
			High RPM, stroked or fuel injected	338HT
1176	Ultra 150	99-05		338LT
	1200STXR	04-05		338HT



RAD VALVES FOR YAMAHA WATERCRAFT

Fits Yamaha Engines: 701(62T) (94-08),
760(64X), 1100(63M) and 1200(65U)



Yamaha	Rad Valve	Replacement Rad Reed
RIVA or R&D	RAD-131R*	PRO-131R
Twin or Triple Intake Manifold		

* Order one set per cylinder, 2 valves for twin, 3 valves for triple cylinders.



BOYESEN POWER REEDS

- The unique dual-petal design
- Quicker acceleration, throttle response and speed.
- Dual-flex epoxy fiber material for maximum longevity and reliability.

Yamaha	Part No.
500 All	022
650 Super Jet	023
650 Wave Runner (All)	023
701 Wave Raider (All)	024
701 FX1 (94-95)	024
701 Pro-VXR (93-94)	024
701 Super Jet (94-95)	024
Wave Blaster (93-95)	024
Wave Raider (Single Carb) (96)	024
Wave Runner III (94-97)	024
701 Super Jet (96-12)	026
Wave Blaster (96)	026
Wave Raider (94-96)	026
Wave Raider DLX (95-96)	026
Wave Runner XL (99-04)	026
Wave Venture (95-98)	026
GP760(97-00), 760 Waves All (95-99)	029
1100 All (95-97)	028
GP1200(97-99), SUV1200(99-04)	033
XL1200(98)	033

Kawasaki	Part No.
550SX (91-95)	014
650SX/X2/SC/SS/ST/TS (All)	012
750SX/SXI/SXI-Pro (All)	013
750SS/STS/XI/ZXI (All)	013
800 SX-R (03-12)	013
900ZXI (-97), STX (97-01), STS (01)	020
1100ZXI/STX (96-03)	021
Ultra 130 (01-04)	036
STX-R 1200 (02-05), Ultra 150 (99-05)	021

Polaris	Part No.
650 All (92-95)	016
SL750 (93-95), SLT750 (94-95)	016
SL780 (96-97), SLT780 (96-97)	016
SLT780 (96-97), SLX780 (96)	016
SLX785 Pro (97-01)	016
700 All (-02)	013
Octane (02-04)	013
800 DI (02-04)	013
Hurricane (96-97)	013



BOYESEN PRO SERIES REEDS

- Quicker acceleration for that all important holeshot.
- Crisper mid-range allowing you to pull that extra boat length.
- Carries RPMs further past peak allowing you to run that steeper pitched impeller for increased top end.
- Easy starting and smoother idling for those dreaded no-wake zones.
- Increased life over traditional carbon fiber reeds.

Yamaha	Stock/Limited	Hi-Performance
700 Wave Raider (All)	—	PRO-35
701 FX1 (94-95)	—	PRO-35
701 Pro-VXR (93-94)	—	PRO-35
701 Super Jet (94-95)	—	PRO-35
701 Super Jet (96-12)	PRO-36	PRO-37
Wave Blaster (93-95)	PRO-36	PRO-37
Wave Blaster (96)	PRO-36	PRO-37
Wave Raider (94-96)	PRO-36	PRO-37
Wave Raider, Single Carb (96)	—	PRO-35
Wave Raider DLX (95-96)	PRO-36	PRO-37
Wave Runner III (94-97)	—	PRO-35
Wave Runner XL (99-04)	PRO-36	PRO-37
Wave Venture (95-98)	PRO-36	PRO-37
GP760 (97-00)	PRO-38	PRO-39
760 Waves All (96-99)	PRO-38	PRO-39
1100 All (95-97)	PRO-40	—
GP1200 (97-99), GP1200R (99)	PRO-77	PRO-78
SUV1200 (99-04), XL1200 (98)	PRO-77	PRO-78

Kawasaki	Stock/Limited	Hi-Performance
750 All	PRO-24	PRO-25
800 SX-R (03-12)	PRO-24	PRO-25
900 All (-96)	PRO-76	—
1100 All (96-03)	PRO-57	—
Ultra 150/STX-R1200 (99-05)	PRO-57	—

Polaris	Stock/Limited	Hi-Performance
700 All (thru 04)	PRO-26	PRO-27
Octane (02-04)	PRO-26	PRO-27
750 All (93-95)	—	PRO-29
780 All (98-97)	—	PRO-31
785 SLX Pro (97-01)	—	PRO-31



BOYESEN REED VALVE STUFFER KIT

Kit includes a complete engine set of Boyesen 3D Reed Valve Stuffers and Boyesen PRO Series reeds.

Yamaha	Part No.
Reed Valve Stuffer Kit GP1200R (00-02), XL/XLT 1200 (99-05), GP1300R (03-08)	RSK-306
Replacement Reed *Must use with Boyesen Stuffer	PRO-128

FOUR STROKE
INTAKE SYSTEMS
ENGINE/GASKETS
EXHAUST
DRIVE LINE HANDLING
ELECTRICAL
WATERLINE /BILGE
STEERING & CONTROLS
BODY
ACCESSORIES
SERVICE TOOLS /HARDWARE
CHEMICAL



MOTO TASSINARI VFORCE3 THE FEATURES AND BENEFITS OF VFORCE TECHNOLOGY

The VForce3 Reed Valve System incorporates features you won't find with other system on the market. With such features as twice the reed tip surface, radius cage surface, snap-together construction, proprietary carbon fiber recipes and more. By doubling the reed tip surface the petals now only need to open half as far to have the same flow as a stock style cage. This is a significant advantage when you factor in that a reed petal opens and closes 133 times per second at 8,000 rpm. The petals are only traveling half the distance of a stock style cage, so now fatigue to the petal has been greatly reduced, increasing petal life. This design also enables the valve to drastically improve the entire powerband with a significant boost in the bottom and mid. Instant throttle response is an understatement! The petals now sit on a radius surface to create a "pre-loading" effect that improves an already snappy acceleration. Our new cage design now allows the reed petal tips to be recessed into the cage itself. This allows for a cushioning of the reed tips and also discourages the possibility of any back-flow.

SYMMETRICAL REED PETALS:

The VForce3 now uses symmetrical reed petals for both the inner and outer reed petals. No longer will you need to be concerned with having both "inner" and "outer" reed petals.

SNAP-TOGETHER CONSTRUCTION:

The VForce3 Reed Valve System incorporates the industry's first and only patented snap together reed valve design. The entire assembly is completely screw free, meaning that when reed petals need changing the job is now literally a "SNAP".

CUSTOM AIR-GUIDES:

Custom air guides specific to each individual application ensure the maximum airflow and performance benefits of the VForce3 reed valve system in your pwc.

PROPRIETARY CARBON LAY-UP:

Moto Tassinari continues to test and develop new "recipes" for our carbon fiber used in the VForce3 Reed Valve system. In fact Moto Tassinari specs our own exclusive recipes for all the carbon



fiber we use, you can be assured you'll never get "generic" carbon fiber designed for somebody and something else, when you buy VForce.

TWICE THE REED TIP SURFACE:

The unique and proven design of the VForce3 Reed Valve System doubles the available reed tip surface over a conventional reed valve design. By doubling the effective reed tip surface it enables the engine to get more air with less effort. The number one rule in two-stroke motor modification is More Air = More Horsepower.

AIRFOIL TECHNOLOGY:

The new reed cage design on the VForce3 Reed Valve system incorporates airfoil shaped (flat on bottom/curved on top) reed tip surfaces which in turn increases the velocity of the fuel/air mixture as it passes through and over, creating the optimum fuel atomization.

Yamaha	VForce 3	Repl. VForce 3 Pedal	Repl. VForce 3 Gasket
All Yam Triples*	V3140-794-3	3P794A	G3140**
All Yam Twins*	V3140-794-2	3P794A	G3140**

*Not compatible for older WaveBlasters and GPR (Power valve cylinders) applications.

**Gaskets are sold individually.

Kawasaki	VForce 3	Repl. VForce 3 Pedal	Repl. VForce 3 Gasket
All Kaw Triples	V3150-794-3	3P794A	G3150**
All Kaw Twins	V3150-794-2	3P794A	G3150**

**Gaskets are sold individually.

Polaris	VForce 3	Repl. VForce 3 Pedal	Repl. VForce 3 Gasket
Octane 777	V3130-794A-2	3P794A	—

**Gaskets are sold individually.



VFORCE DELTA 2



• Sold as complete kit per engine.

Sea Doo	VForce Delta 2	Delta 2 Repl. Pedal	Delta 1 Repl. Pedal (97-99)	Repl. Gasket
GSX/GTX/XP 951	V2W121-2	2P127-1	DP120-1	6755**

Polaris	VForce Delta 2	Delta 2 Repl. Pedal	Delta 1 Repl. Pedal (97-99)	Repl. Gasket
SL650,SL/SLT750	V2W131-3	2P117-1	-----	4050**
SLX780/785 Pro	V2W132-3	2P117-1	-----	4050**

Yamaha	VForce Delta 2	Delta 2 Repl. Pedal	Delta 1 Repl. Pedal (97-99)	Repl. Gasket
All Yamaha Triples	V2W140-3	2P127-1	DP120-1	4430**
All Yamaha Twins***	V2W140-2	2P127-1	DP120-1	2830**

***Except older Blasters

Kawasaki	VForce Delta 2	Delta 2 Repl. Pedal	Delta 1 Repl. Pedal (97-99)	Repl. Gasket
All Kawasaki Triples	V2W150-3	2P127-1	DP120-1	MT6150**
All Kawasaki Twins	V2W150-2	2P127-1	DP120-1	MT6150**

**Gaskets are sold individually.

ROTARY VALVE PARTS



ROTARY VALVE TIMING WHEEL

Sea Doo	Part No.
Hot Products Rotary Valve Timing Wheel	012-170



ROTARY SHAFT PULLER

Special rotary shaft puller tool for Sea Doo PWC.
 Fits: Most 580cc, 650cc, 720cc, and 800cc Sea Doo engines.
 (6mm thru bolt included)
**Lubrication of all areas is required before using this tool*

Sea Doo	Part No.
Rotary Shaft Puller	B-204

SEA DOO ROTARY VALVE SHAFT AND PARTS

Descriptions	OEM#	Part No.
A. Rotary Valve Shaft 580/650/720	293-837-251	010-455
B. Rotary Valve Shaft 800	290-837-351	010-457
C. Rotary Valve Shaft Gear only (14 teeth) 580/650/720/800 (89-up)	420-935-735	010-450
D. Rotary Cover O-Ring 580/650/720	293-300-023	6250
E. Rotary Cover Manifold O-Ring 800	290-831-765	6628
F. Rotary Shaft O-Ring 580/650/720/800	293-300-024	6260
G. Rotary Shaft Oil Seal 580/650/720/800	290-930-580	009-779
H. Rotary Shaft Bearing 580/650/720/800	290-932-032 290-932-797	010-225 010-226

Descriptions	OEM#	Part No.
I. Rotary Shaft Spring 580/650/720/800	290-938-810	010-453
J. Rotary Shaft Snap Ring - Large 580/650/720/800	290-845-260	010-483
K. Rotary Shaft Snap Ring - Small 580/650/720/800	290-932-032	010-482
L. Rotary Shaft C-Clips 580/650/720/800	290-845-160	010-454
M. Rotary Spring Holder 580/650/720/800	420-827-430	010-484-01
N. Rotary Bearing Washer 580/650/720/800	420-227-439	010-459
O. Rotary Shaft Barrel 580/650/720/800	290-847-282	010-484

WSP STAINLESS STEEL ROTARY VALVES



Model	Year	Opening Duration	Part No.
580 All	94-96	147°	006-147
650 All	94-95	159°	006-159
720	95-02	159°	006-159
785	95-02	159°	006-159



SUTIWAS "SAM" CHAISIRIVICHIEAN
 MOTOR FIELD THAILAND • 2010 KING'S CUP

FOUR STROKE	INTAKE SYSTEMS	ENGINE/ GASKETS	EXHAUST	DRIVE LINE HANDLING	ELECTRICAL	WATERLINE /BILGE	STEERING & CONTROLS	BODY	ACCESSORIES SERVICE TOOLS /HARDWARE	CHEMICAL
----------------	-------------------	--------------------	---------	------------------------	------------	---------------------	------------------------	------	-------------------------------------------	----------



RACING FLAME ARRESTORS (without Cotton Media)

Experience increased horsepower and engine protection with K&N Personal Watercraft flame arrestors for both normal and race applications. K&N "RACING ONLY" flame arrestors have an epoxied screen filter that does not have the cotton media.

K&N flame arrestors replace the restrictive factory airbox. In most cases an adapter is required (for adapters see pages 30 & 31) to mount the flame arrestor onto the carburetor. Some watercraft may require a slight adjustment to the carburetor's fuel circuits to allow for optimum performance.

4" Tall



59-2040R
STAINLESS TOP



59-2040RK
COMPOSITE TOP

Height	Top Color	Part No.
4"	Black Composite	59-2040RK
4"	Stainless Steel	59-2040R
Outerwears Water Repellent Pre-Filter		WR145-10-4DT

2-1/2" Tall



59-2042R
CHROME TOP



59-2042RK
COMPOSITE TOP

Height	Top Color	Part No.
2-1/2"	Black Composite	59-2042RK
2-1/2"	Chrome	59-2042R
Outerwears Water Repellent Pre-Filter		WR145-115-25DT

Outerwears Racing Accessories

The Outerwears Pre-filter is an excellent solution to prevent water from entering into the engine without restricting air flow or causing a loss in performance. An Outerwears Pre-Filter is designed to be water repellent and will reduce the risk of water entering through an air intake system. Outerwears offers water repellent pre-filters for K&N, Tau Ceti, ProK and R&D performance air filters and flame arrestors.



G.

2-3/4" Tall



Height	Top Color	Part No.
2-3/4"	Black Composite	59-2046
Water Repellent Pre-Filter		WR125-2DT



A.

B.

C.

D.

E.

F.

Description	Flame Arrestor Type	Part No.
A. 4.25" x 3" Taper/4" Tall	K&N 59-2040R/RK	WR145-10-4DT
B. 4.25" x 3.5" Taper/2.5" Tall	K&N 59-2042R/RK	WR145-115-25DT
C. 4" dia/1.75" Tall	Tau Ceti 53-4270	WR125-15DT
D. 4" dia/2.25" Tall	Tau Ceti 53-4272. ProK	WR125-2DT
E. 4" dia/2.25" Tall (Open Top)	Tau Ceti 53-4272. ProK	WR125-225
F. 4" x 3" Taper/3.5" Tall	Tau Ceti 53-4275	WR125-10-35DT
G. Pro-Lock SD951/2.5" Tall	R&D 203-9500	WR30-25DTPRO



2011 BLOWSION SURF SLAM
PACIFIC CITY, OREGON

Hot Products

HOT PRODUCTS TORNADO SERIES FILTERS

by Tau Ceti



The all new Hot Products Tornado Series Filters by Tau Ceti is the newest performance filter available for the pwc performance industry. The new Tornado Series Filters feature a velocity cone with proprietary designed air channels to increase the air flow into the induction system. These filters are made using the same top quality materials as the Tau Ceti Pro Series Filters. The velocity cone is clear/smoke color and the filter top features an aluminum filter top ring.

The universal rubber mount will fit any personal watercraft with a stock carburetor using the appropriate adapter (for adapters see pages 120 & 121). No re-jetting is necessary on stock boats. Each filter includes a stainless steel filter clamp for installation.

See page 93 for Tau Ceti color images.

Description	Filter Top Color	Part No.
Hot Products Round Filter 2 1/2"	Silver	53-4274-SIL
Hot Products Round Filter 2 1/2"	Black	53-4274-BLK
Hot Products Round Filter 2 1/2"	Blue	53-4274-BLU
Hot Products Round Filter 2 1/2"	Green	53-4274-GRN
Hot Products Round Filter 2 1/2"	Red	53-4274-RED
Tau Ceti Water Repellent Pre-Filter	Black	PFTCP-25
Outerwears Water Repellent	----	20-2761-01/HOTP
Pre-Filter Clear Top		



Description	Filter Top Color	Part No.
Hot Products Round Filter 2"	Silver	53-4273-SIL
Hot Products Round Filter 2"	Black	53-4273-BLK
Hot Products Round Filter 2"	Red	53-4273-RED
Outerwears Water Repellent	----	20-2760-01/HOTP
Pre-Filter Clear Top		

Description	Filter Top Color	Part No.
Hot Products Round Filter 1.5"	Silver	53-4271-SIL
Hot Products Round Filter 1.5"	Black	53-4271-BLK
Outerwears Water Repellent	----	20-2762-01/HOTP
Pre-Filter Clear Top		



OUTERWEARS WATER REPELLENT PRE-FILTERS

These new Outerwears Pre-Filters are specially designed for Hot Products Tornado Series Filters and feature a clear top, with black water repellent material.

Description	Part No.
Pre-Filter for 53-4274 2-1/2" Tall Filters	20-2761-01/HOTP
Pre-Filter for 53-4273 2" Tall Filters	20-2760-01/HOTP
Pre-Filter for 53-4271 1-1/2" Tall Filters	20-2762-01/HOTP

FOUR
STROKE

INTAKE
SYSTEMS

ENGINE/
GASKETS

EXHAUST

DRIVE LINE
HANDLING

ELECTRICAL

WATERLINE
/BILGE

STEERING
& CONTROLS

BODY

ACCESSORIES

SERVICE TOOLS
/HARDWARE

CHEMICAL



K&N FILTER APPLICATIONS

FOUR STROKE
INTAKE SYSTEMS
ENGINE/GASKETS
EXHAUST
DRIVE LINE HANDLING
ELECTRICAL
WATERLINE /BILGE
STEERING & CONTROLS
BODY
ACCESSORIES
SERVICE TOOLS /HARDWARE
CHEMICAL

SEA DOO	Stock Carb Type & Quantity	Race K&N P#	Regular K&N P#	Adapter P#
580GTX 92-94	2/38M	59-2040RK	59-2910	53-4460
580GT 89-96	1/38M	59-2042RK	59-2010	53-4460
580GTS 93-96	1/38M	59-2042RK	59-2010	53-4460
580SP 88-96	1/38M	59-2042RK	59-2010	53-4460
580SPX 92-94	2/38M	59-2042RK	59-2910	53-4460
580 SPI 88-96	1/38M	59-2042RK	59-2010	53-4460
650XP 94	2/40M"1"	59-2042RK		53-4465
650XP 90-93	2/40M"1"	59-2042RK		53-4465
650GTX 95	2/40M"1"	59-2040RK		53-4465
650SPX 95	2/40M"1"	59-2042RK		53-4465
720XP 95	2/40M"1"	59-2042RK		53-4465
720GTI 97-99	1/40M"1"	59-2040RK		53-4465
720GTI 96	2/40M"1"	59-2040RK		53-4465
720GTS 97-00	1/40M"1"	59-2042RK	59-2010	53-4465
720SP 97	1/40M"1"	59-2042RK	59-2010	53-4465
720SPX 96	2/40M"1"	59-2042RK		53-4465
720HX95-97	2/40M"1"	59-2040RK	59-2010	53-4465
720GS 97-00	1/40M"1"	59-2040RK	59-2010	53-4465
720GSI 97	1/40M"1"	59-2040RK		53-4465
800GTX 96-97	2/40M"1"	59-2040RK		53-4465
800GSX 96-97	2/40M"1"	59-2040RK		53-4465
800XP 95-97	2/40M"1"	59-2042RK		53-4465
800SPX 97-99	2/40M"1"	59-2042RK		53-4465
950GSX LTD 97-99	2/46M"1"	59-2042RK		not required
950XP LTD 98-00	2/46M"1"	59-2042RK		not required
950GTX LTD 98-99	2/46M"1"	59-2042RK		not required
YAMAHA				
W/Jammer 500 88-89	1/38M	59-2042RK	59-2000	53-4460
W/Runner 500 88-89	1/38M	59-2042RK	59-2000	53-4460
W/runner 650 90-95	1/44M	59-2042RK	59-2000	53-4480
W/Runner III 650 90-95	1/44M		59-2020	Not Available
VXR 650 91-95	1/44M		59-2020	Not Available
Super Jet 650 90-93	1/44M	59-2042RK	59-2000	53-4480
W/Raider 701 94-95	2/38M	59-2040RK		53-4462
W/Raider 70196-97	1/44M	59-2040RK		53-4482
W/Venture 701 95-98	2/38M	59-2040RK		53-4462
W/Blaster 701 96-97	2/38M	59-2042RK		53-4462
W/blaster 701 93-95	1/44M		59-2020	Not Available
Super Jet 701 94-95	1/44M	59-2042RK	59-2000	53-4480
Super Jet 701 96-09	2/38M	59-2042RK		53-4460
FX1 701 94-95	1/44M	59-2042RK	59-2000	53-4480
XL700 95-00	2/38M	59-2042RK		53-4462
GP760 97-00	2/44M	59-2040RK		53-4480
XL760 98-99	2/44M	59-2040RK		53-4482
W/Raider 760 96	2/44M	59-2040RK		53-4482
W/blaster II 760 96-97	2/44M	59-2040RK		53-4480
W/Venture 760 96-98	2/44M	59-2040RK		53-4480
GP800 98-00	2/44M	59-2044R		53-4466
W/Raider 1100 95-06	3/38M	59-2040RK		53-4462
W/Venture 1100 96-98	3/38M	59-2040RK		53-4462
XL1200 98	3/44M	59-2040RK		53-4480
GP1200 97-99	3/44M	59-2040RK		53-4480
GP1200R 00	3/44M	59-2044R		53-4466
KAWASAKI				
JS300 86-91	1/38M	59-2042RK	59-2000	53-4460
JS400 74-76	1/38M	59-2042RK	59-2000	53-4460
JS440 77-90	1/38M	59-2042RK	59-2000	53-4460
JS440 91-92	1/42K	59-2042RK	59-2000	53-4440
JS550 82-85	1/38M	59-2042RK	59-2000	53-4460
JS550 86-90	1/44M	59-2042RK	59-2000	53-4480

KAWASAKI	Stock Carb Type & Quantity	Race K&N P#	Regular K&N P#	Adapter P#
JS550SX 91-95	1/42K	59-2042RK	59-2000	53-4440
650X2 89-94	1/28K	59-2042RK	59-2015	Not Available
JS650SX 89-94	1/28K	59-2042RK	59-2000	Not Available
650TS 89-96	1/38K	59-2042RK		53-4440
650SC 90-95	1/38K	59-2042RK	59-2000	53-4440
750SX 92-95	1/40K	59-2042RK	59-2860	53-4440
750SX1 95	1/38K	59-2042RK		53-4450
750SX1 96-97	2/40M"1"	59-2042RK		53-4465
750SX1 PRO 98-00	2/40M"1"	59-2042RK		53-4465
750SS 92-98	1/40K	59-2042RK	59-2860	53-4440
750XI 93-97	2/40K	59-2042RK		53-4440
750XIR 94	2/40K	59-2042RK		53-4440
750ST 94-95	1/40K	59-2042RK	59-2860	53-4440
750STS 95-97	2/38K	59-2042RK		53-4450
750Z1 95-98	2/38K	59-2042RK		53-4450
800SX-R 03-09	2/40M"1"	59-2042RK		53-4465
900Z1 95-97	3/38K	59-2040RK		53-4450
900STX 97-99	3/38K	59-2040RK		53-4450
1100Z1 96-97	3/38K	59-2040RK		53-4450
1100STX 97-99	3/38K CDCV	59-2040RK		Not Available
ULTRA150 99-00	3/40K CDCV	59-2040RK		Not Available
POLARIS				
SL650 92-95	3/38M	59-2042RK		53-4460
HURRICANE700 96-97	2/38K	59-2042RK		53-4440
SL/SLT700 96-97	2/38K	59-2042RK		53-4440
SLH700 98-00	2/38K	59-2042RK		53-4440
SL/SLT750 93-95	3/38M	59-2042RK		53-4460
SL/SLT780 96-97	3/38M	59-2042RK		53-4460
SLX780 95-96	3/38M	59-2042RK		53-4460
SLXPRO785 97-00	3/44M	59-2042RK		53-4480
SL900 96-97	3/38K	59-2042RK		53-4440
SL/SLTX1050 96-00	3/38K	59-2042RK		53-4440
SLXH1050 98-99	3/38K	59-2042RK		53-4440
Genesis 99-00	3/38K	59-2042RK		53-4440
1200 PRO 00	3/38K	59-2042RK		53-4440
Virage/TX 00	3/38K	59-2042RK		53-4440
TIGER SHARK				
Daytona650 92-93	1/46M	59-2042RK		53-4490
Daytona650 95	2/38M	59-2042RK		53-4460
MonteCarlo650 94-95	1/46M	59-2042RK		53-4490
MonteCarlo650 96	1/44M	59-2042RK		53-4480
MonteCarlo650 97	1/40M"1"	59-2042RK		53-4465
Montego650 94-96	1/44M	59-2042RK		53-4480
Montego650 97	1/40M"1"	59-2042RK		53-4465
Barracuda650 93-95	1/46M	59-2042RK		53-4490
Daytona770 96-97	2/40M"1"	59-2042RK		53-4465
MonteCarlo770 96-97	2/40M"1"	59-2042RK		53-4465
MonteCarlo900 95	3/44M	59-2042RK		53-4480
MonteCarlo900 96	3/40M"1"	59-2042RK		53-4465
Daytona1000 97-98	3/40M"1"	59-2042RK		53-4465
MonteCarlo1000 97-98	3/40M"1"	59-2042RK		53-4465
TS640 98-99	1/38M	59-2042RK		53-4460
TS770 98-99	1/38M	59-2042RK		53-4460
TS770R 98-99	2/38M	59-2042RK		53-4460
TS770L 98	2/38M	59-2042RK		53-4460
TS770L 99	1/38M	59-2042RK		53-4460
TS1000 98	3/40M"1"	59-2042RK		53-4465
TS1000L 98	3/40M"1"	59-2042RK		53-4465
TS1100R	3/40M"1"	59-2042RK		53-4465



2012 IJSBA Hot Products
MARK HAHN MEMORIAL
HAVASU 300 ENDURANCE RACE IN
LAKE HAVASU CITY, ARIZONA
AWARDS CEREMONY

HOT PRODUCTS ALUMINUM AIR FILTER ADAPTERS FOR MIKUNI CARBURETORS. SOLD INDIVIDUALLY.



Mikuni		Part No.
38mm	38mm Bore	53-4460
44mm	46mm Bore	53-4480
46mm	48mm Bore	53-4490



Mikuni	Part No.
OEM 40mm "I" Series (48mm Bore)	53-4465
Sea Doo HX/XP, K750 SXI 96-02, K800SX-R 03-12	



Mikuni	Part No.
OEM Carb Yamaha	53-4466
GPR Series (57mm Bore)	



OIL INJECTION SPACER PLATES

Description	Part No.
Mikuni 44mm	53-4485
Mikuni 46mm	53-4495
Press in Nipple (1/8") only	53-9936



For Oil Injection

Mikuni	Part No.
38mm with oil injection fitting	53-4462

HOT PRODUCTS ALUMINUM AIR FILTER ADAPTERS FOR KEIHIN CARBURETORS

ALL ADAPTERS SOLD INDIVIDUALLY



Keihin	Part No.
38/40/42mm (50mm Bore)	53-4440



Keihin	Part No.
OEM Carb (44mm Bore)	53-4450
K750 SXI-95, 750ZXI, K900/1100ZXI	



REPLACEMENT THROTTLE CABLES

Yamaha	Part No.
500WR '87-'93, 650SJ '90-'93, EUO-U7252-01	05-0226
650 WR/WRIII/LX/WR VXR '90-'96	
701 SJ '90-'95, WR701 '96-'97, W/B701 '93-'95, 701WRII GP '94-'95, 701 WR Pro VXR '93-'94, 701 WRII '97	
701 WR DX 95, 701 WV 95-96	002-057
1100 WR 95-96, 1100 WV 96	

Kawasaki	Part No.
440 '77-'86, 550 '82-'86 Shaft End Style Cable	58-3121

FOUR STROKE
INTAKE SYSTEMS
ENGINE/GASKETS
EXHAUST
DRIVE LINE HANDLING
ELECTRICAL
WATERLINE /BILGE
STEERING & CONTROLS
BODY
ACCESSORIES
SERVICE TOOLS /HARDWARE
CHEMICAL

PERFORMANCE FILTER KITS FOR TWO STROKE MOTORS

FOUR STROKE
INTAKE SYSTEMS
ENGINE/GASKETS
EXHAUST
DRIVE LINE HANDLING
ELECTRICAL
WATERLINE /BILGE
STEERING & CONTROLS
BODY
ACCESSORIES
SERVICE TOOLS /HARDWARE
CHEMICAL



Kawasaki **Part No.**
1200STXR Stock Carb/Stock Pipe **200-01240**



Kawasaki **Part No.**
800SX-R Stock Carb (I Series Adapters Included) **200-00800**
800SX-R Aftermarket Carb **200-00120**
120mm center to center (Adapters not included)



SD 951
#203-95000

Sea Doo **Part No.**
951 All **203-95000**



Yamaha **Part No.**
GP1300R Stock Fuel Injection **200-13143**
GP1200R/XLL/XLT1200 **200-00142**



Ultra 150 #200-00140

Kawasaki **Part No.**
Ultra 150 1200cc Stock Carbs **200-00140**



GP 1300R POWER STACK AIR FILTER KIT

The R&D GP 1300R Power Stack Air Filter Kit is designed to assemble on to the front of the OEM air plenum box. The R&D Power stack adds bottom and mid range power performance while increasing engine RPM's.

Yamaha **Part No.**
GP 1300R for Stock Air Box **200-13100**



RIVA POWER FILTER FOR GP1300R

Power filter fits directly onto OEM air box assembly. Kit comes with water repellent filter.

Yamaha **Part No.**
Flame Arrestor, Power Filter Kit GP1300R (60T) **RY1312**

PERFORMANCE FILTER KITS FOR FOUR STROKE MOTORS

FOR ADDITIONAL 4-STROKE PRODUCTS SEE THE FOUR STROKE SECTION



R&D 12F/15F FLAME ARRESTOR

The R&D filter kit will unleash horsepower trapped in the restrictive stock air box. The exclusive lightweight filter design couples to the OEM throttle body, and is engineered with a large plenum to deliver massive cubic air volume and improved air speed. Kit comes complete with all necessary hardware.

Kawasaki	Part No.
R&D 12F/15F Flame Arrestor (Replacement for R&D #215-15010)	215-15011



R&D REPLACEMENT PERFORMANCE FILTER

The new R&D Replacement Performance Filter replaces the stock restrictive perforated filter plate and allows for improved airflow. Amounts directly into the stock filter box and retains the OEM look. The improved airflow increases throttle response, RPM, and top speed.

Kawasaki	Part No.
STX-12F/15F	215-15000

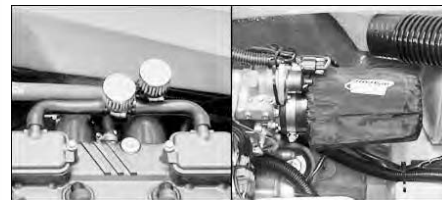

RIVA ULTRA LX/STX-F PERF. POWER FILTER KIT

- Increases airflow and power.
- Installs easily.
- Mounts directly onto stock throttle body.
- Built to our specifications by K&N.
- Includes two smaller K&N filters for engine breather hoses and water repellent pre-filter cover for primary filter.

Kawasaki	Part No.
Ultra LX, STX-F Power Filter	RK13085



R&D POWER PLENUM FLAME ARRESTER

The R&D High Flow Power Plenum replaces the restrictive stock flame arrester allowing more improved airflow, why? Because more air flow with less restriction means more power!

Yamaha	Part No.
FX 140/Cruiser FX HO/Cruiser	200-00144



R&D HIGH FLOW POWER PLENUM AIR BREATHER

The R&D High flow breather is a direct replacement for the stock breather in the OEM air box. Water tested to deliver improved throttle response, acceleration and top speed with 50-100 RPM increase.

Yamaha	Part No.
FX 140/Cruiser FX HO/Cruiser	200-00143



R&D VELOCITY STACK KIT

The R&D Velocity Stack Kit is a direct bolt-on kit that replaces the restrictive OEM stacks. Designed to increase air velocity into the throttle bodies producing improved throttle response and top end speed. Easily installs with OEM hardware.

Yamaha	Part No.
FX 140/Cruiser FX HO/Cruiser	206-00140



R&D VX110 PERFORMANCE AIR FILTER KIT

The new R&D Performance Air Filter for the VX 110 is now available. The R&D High Flow Filter design replaces the restrictive stock filter inside the stock air box, allowing improved air flow.

Yamaha	Part No.
VX110 for Stock Carb Air Box	200-00110



R&D VX110 POWER FILTER KIT

Screen-type filter element replaces restrictive stock air filter. Extended intake tube draws cooler air into engine significantly improving performance. Includes pre-filter.

Yamaha	Part No.
VX110 Power Filter Kit	RY13030



2011 IJSBA WORLD FINALS
VENDOR ALLEY
LAKE HAVASU CITY, ARIZONA

FOUR STROKE	INTAKE SYSTEMS	ENGINE/GASKETS	EXHAUST	DRIVE LINE HANDLING	ELECTRICAL	WATERLINE /BILGE	STEERING & CONTROLS	BODY	ACCESSORIES	SERVICE TOOLS /HARDWARE	CHEMICAL
-------------	----------------	----------------	---------	---------------------	------------	------------------	---------------------	------	-------------	-------------------------	----------